

Contents	<u>5</u>
Index of Types	<u>9</u>

Selector Guide	<u>11</u>
Applications	<u>19</u>

General Technical Information	<u>23</u>
--------------------------------------	------------------

Data Sheets	<u>45</u>
--------------------	------------------

Standardized R/T Characteristics	<u>107</u>
---	-------------------

Mounting Instructions	<u>139</u>
Quality	<u>145</u>
Environmental Protection, Climatic Conditions	<u>151, 153</u>

Taping and Packing	<u>155</u>
Symbols and Terms	<u>161</u>
Subject Index	<u>163</u>

SIEMENS

SCS on the Internet

Creating new links

As of now you can tie up with Passive Components and Electron Tubes Group plus Siemens Matsushita Components on the Internet. On our home page under

<http://www.siemens.de/pr/index.htm>

you'll find the latest short form catalogs, data books, technical articles and more subjects too. You can view the documents on-line, or download them to your PC. The "Installation" menu item tells you how to do it. Thanks to the integrated search function, you only have to enter key terms to go straight to the right document. And of course, you can get in touch with us direct by E mail at any time.

SCS - dependable, fast and competent

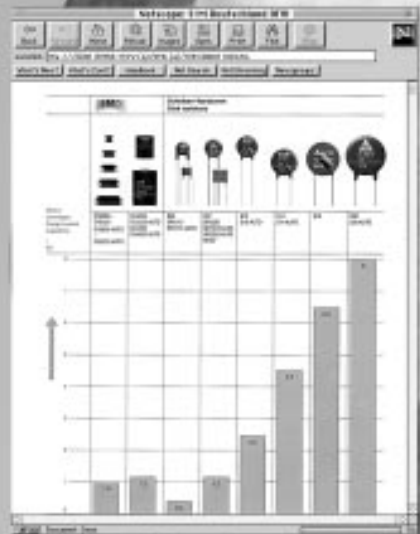

NTC Thermistors

SIEMENS

Now order even more

We've really got things in store

When you need bigger batches than usual, we don't leave you with empty hands. We've pushed up maximum order quantities quite a bit, all of ten times for ceramic chip capacitors for example. But we've got lots more in



store for you, like SCS depots right there in our plants, extra stock with distributors, and experienced sales engineers on the spot around the world. An extensive range of non-SCS components is available too – just contact us.

SCS – dependable, fast and competent

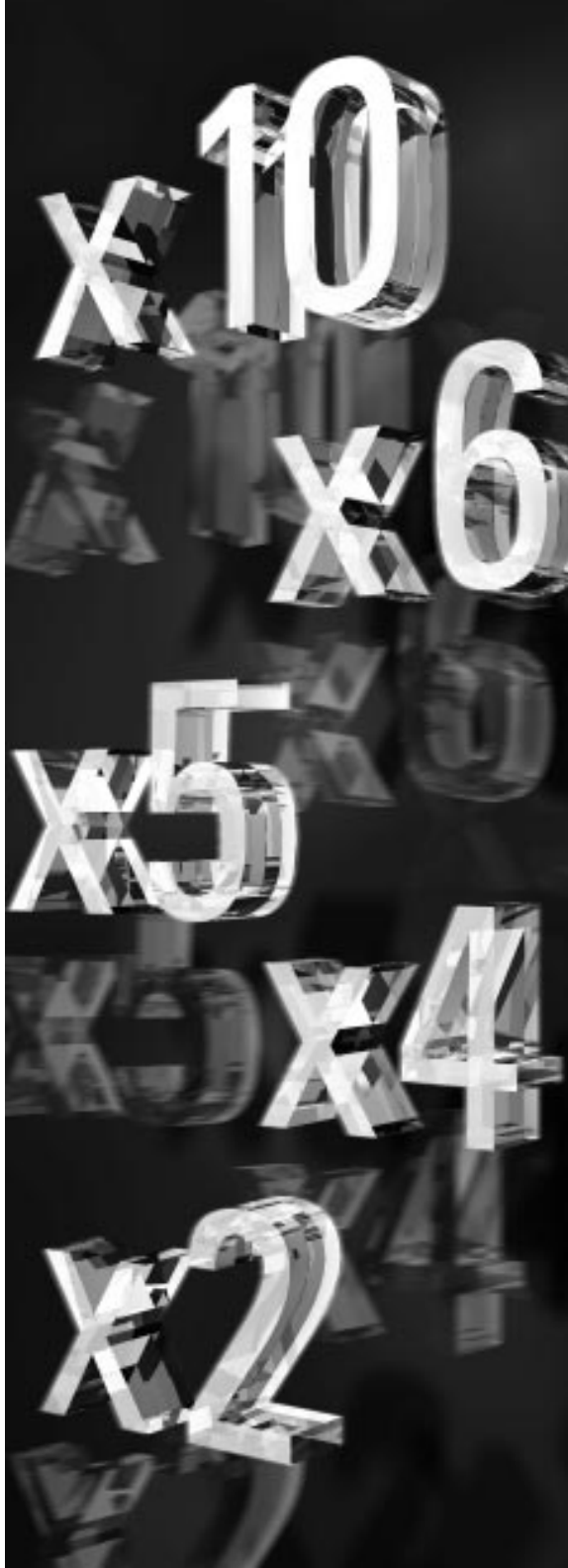

Contents

Index of types	9
Selector guide	11
Applications	19
General technical information	23
1 Definition	23
2 Manufacture	23
3 Characteristics	23
3.1 Unloaded NTC thermistors	24
3.1.1 Temperature dependence of resistance	24
3.1.2 <i>B</i> value	24
3.1.3 Tolerance	25
3.1.4 Temperature coefficient α	27
3.1.5 Zero-power measurement	27
3.2 Electrically loaded NTC thermistors	27
3.2.1 Voltage/current characteristic	28
3.2.2 Behavior in different media	30
3.2.3 Maximum power rating <i>P</i>	30
3.2.4 Dissipation factor δ_{th}	30
3.2.5 Heat capacity C_{th}	30
3.2.6 Thermal cooling time constant τ_c	31
3.2.7 Thermal time constant τ_a	31
3.2.8 Ageing and stability	31
4 Application notes	32
4.1 Applications utilizing the influence of ambient temperature on resistance (self-heating negligible!)	32
4.1.1 Temperature measurement	32
4.1.2 Linearizing the <i>R/T</i> characteristic	32
4.1.3 Temperature compensation	34
4.2 Applications utilizing the non-linear voltage/current characteristic (in self-heated mode)	35
4.2.1 Inrush current limiting	35
4.2.2 Series and parallel connection	36
4.2.3 Self-heating	37
4.2.4 Load derating	38
4.2.5 Restart	38
4.2.6 Dependence of NTC resistance on current	38
4.2.7 Pulse strength	39
4.2.8 Applications	40
4.3 Applications utilizing the influence of the dissipation factor on the voltage/current characteristic	41
4.3.1 Liquid level sensors	41
4.3.2 Flow rate and vacuum measurement	42
4.4 Applications utilizing the current/time characteristic	43

Contents

Data sheets	45
Temperature measurement	45
SMDs	45
Leadless disks	49
Glass-encapsulated NTC thermistors	52
Leaded disks	57
Miniature sensors	69
Probe assemblies	82
Inrush current limiting	99
Standardized R/T characteristics	107
1 Introduction	107
2 Resistance tolerance	108
3 Temperature tolerance	109
4 Characteristics	110
Mounting instructions	139
1 Soldering	139
1.1 Leaded NTC thermistors	139
1.2 Leadless NTC thermistors	139
1.3 SMD NTC thermistors	139
1.3.1 Wettability test	139
1.3.2 Soldering heat resistance test	140
1.3.3 Recommended soldering temperature profiles	140
1.3.4 Notes	142
2 Conductive adhesion	142
3 Clamp contacting	142
4 Robustness of terminations	142
5 Sealing and potting	143
6 Cleaning	143
7 Storage	143
Quality	145
1 Manufacturing process and quality assurance	145
2 General	146
3 Sequence of quality assurance measures	146
3.1 Incoming inspection	146
3.2 Process assurance	146
3.3 Product assurance	146
3.4 Final inspection	146

4	Delivery quality	146
5	Sampling inspection	147
6	Classification of defects	147
7	AQL values	147
8	Incoming inspection by the customer	148
9	Reliability	149
10	Identification and traceability	149
11	Supplementary information	150
	Environmental protection measures	151
	Climatic conditions	153
1	Reliability data	153
2	Operating temperature range / ambient temperatures	153
	Taping and packing	155
1	Taping of SMD thermistors	155
2	Taping of radial-lead NTC thermistors	157
3	Taping of M 87 NTC thermistors	160
4	Packing codes	160
	Symbols and terms	161
	Subject index	163



Siemens Matsushita Components

Now twice as many

2,000 PTC thermistors at once

A hot tip in PTCs for overload protection: our new maximum order level of 2,000 pieces. And with more than 50 different models, we've got a lot more to offer too. Maximum operating voltages from 12 to 550 V, rated currents up to 2.5 A, maximum switching currents of 15 A, plus a broad selection of leaded versions and SMDs.



SCS – dependable, fast and competent

Index of Types

Type	Page	Type	Page
C		S	
C 620	45	S 153	99
C 621	47, 48	S 234	100
K		S 235	101
K 17	52	S 236	102
K 19	53	S 237	103
K 45	82, 83	S 364	104
K 150	49	S 464	105
K 153	57	S 861	69, 71
K 164	58, 59	S 863	75
K 220	50	S 867	74
K 227	90	S 869	81
K 276	86	S 891	63
K 277	88	Z	
M		Z 10	97
M 85	54		
M 87	56		
M 185	55		
M 703	84		
M 820	51		
M 831	92		
M 891	61, 62		
M 912	95		
M 1891	60		
M 2020	94		



Siemens Matsushita Components

A whole lot of ring core chokes

Chokes to your choice

You urgently need particular ring core chokes? That's no problem, we have 200,000 pieces in stock and deliver reliably through SCS. Our automated production guarantees



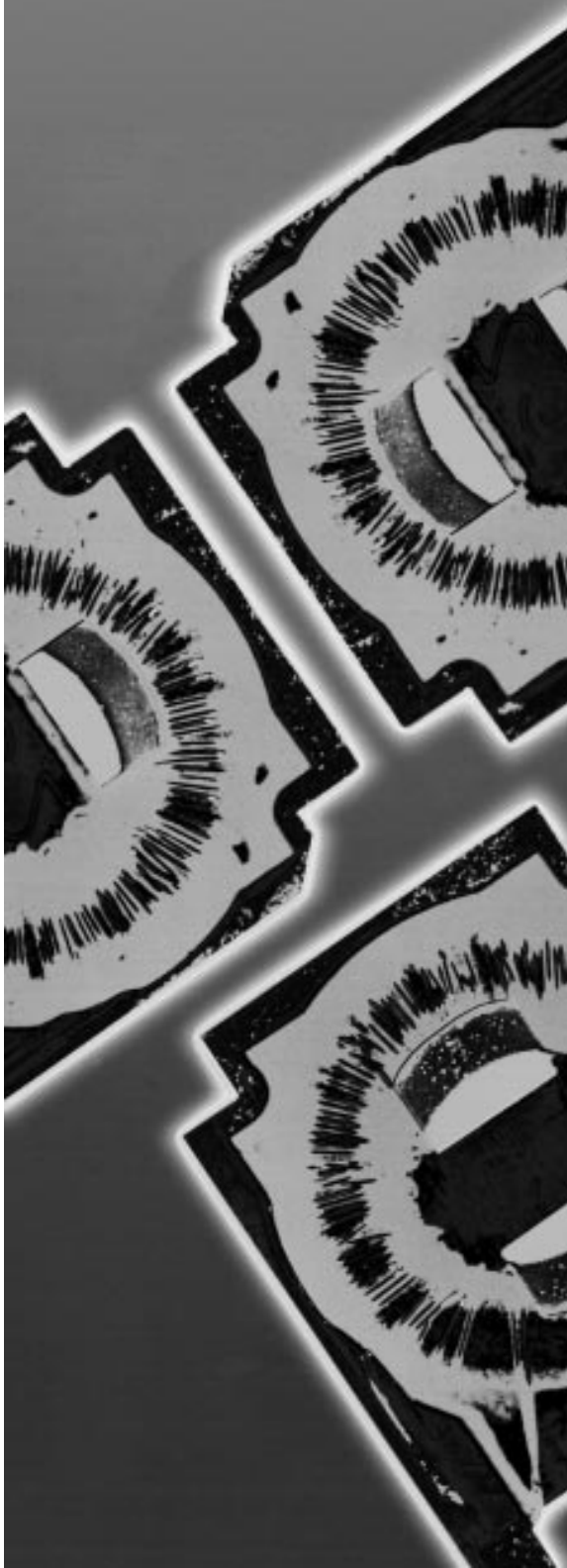

the best of reliability too. It turns out chokes in different versions: flat and upright, with current rated from 0.4 to 16 A. UL and VDE approved, and complying with the latest EMC standards of course.

SCS – dependable, fast and competent



Selector Guide

NTC thermistors for temperature measurement

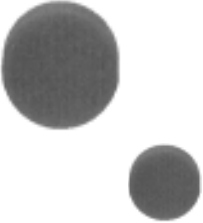
Type	T_A °C	R_N Ω	T_N °C	$\Delta R_N/R_N$	Page	
<i>Surface-mount NTC thermistors</i>						
 	B57620 (C 620)	- 55/125	2,2 k ... 220 k	25	± 5 %; ± 10 %; ± 20 %	45
	B57621 (C 621)	- 55/125	2,2 k ... 680 k	25	± 5 %; ± 10 %; ± 20 %	47
<i>Leadless disks for automotive applications</i>						
	B57150 (K 150)	- 55/155	12,5	100	± 5 %	49
	B57220 (K 220)	- 55/250	2,5 k	20	± 5 %	50
	B57820 (M 820)	- 55/155	39,60 ... 144	100	± 5 %	51

NTC thermistors for temperature measurement

Type	T_A °C	R_N Ω	T_N °C	$\Delta R_N/R_N$	Page	
<i>Glass-encapsulated NTC thermistors with short response time for measuring high temperatures</i>						
	B57017 (K 17)	- 55/250	2,5 k ... 100 k	20	± 5 %; ± 10 %; ± 20 %	52

Selector Guide



NTC thermistors for temperature measurement

Type	T_A °C	R_N Ω	T_N °C	$\Delta R_N/R_N$	Page	
<i>Glass-encapsulated NTC thermistors with short response time for measuring high temperatures</i>						
	B57019 (K 19)	- 55/200	12 k	20	± 5 %; ± 10 %; ± 20 %	53

NTC thermistors for temperature measurement

Type	T_A °C	R_N Ω	T_N °C	$\Delta R_N/R_N$	Page	
<i>Glass-encapsulated NTC thermistors with short response time for measuring high temperatures</i>						
	B57085 (M 85)	- 55/200	4,7 k ... 100 k	25	± 5 %; ± 10 %; ± 20 %	54
	B57185 (M 185)	- 55/200	47 k, 100 k	25	± 3 % ± 5 %	55

NTC thermistors for temperature measurement

Type	T_A °C	R_N Ω	T_N °C	$\Delta R_N/R_N$	Page	
<i>Glass-encapsulated NTC thermistors with short response time for measuring high temperatures</i>						
	B57087 (M 87)	– 55/300	2 k ... 100 k	25	± 10 %	56
<i>Leaded disks for temperature compensation and measurement</i>						
	B57153 (K 153)	– 55/125	4,7 ... 10	25	± 5 %; ± 10 %	57
	B57164 (K 164)	– 55/125	15 ... 470 k	25	± 5 %; ± 10 %;	58
	B57891 (M 1891)	– 55/155	1 k ... 100 k	25	± 5 %; ± 10 %	60
	B57891 (M 891)	– 55/125	1 k ... 470 k	25	± 5 %; ± 10 %	61

Selector Guide



NTC thermistors for temperature measurement

Type	T_A °C	R_N Ω	T_N °C	$\Delta R_N/R_N$	Page
<i>Leaded disks for high-precision temperature measurement</i>					
	B57891 (S 891)	- 55/155	2,2 k ... 100 k	25	$\Delta T = \pm 0,5 \text{ K};$ $\pm 1 \text{ K};$ $\pm 2 \text{ K}$ 63

NTC thermistors for temperature measurement



Type	T_A °C	R_N Ω	T_N °C	ΔT K	$\Delta R_N/R_N$	Page
<i>Miniature sensors for high-accuracy measurement</i>						
	B57861 (S 861)	- 55/155	3 k ... 30 k	25	$\pm 1 \text{ %};$ $\pm 3 \text{ %}; \pm 5 \text{ %}$	69
		- 40/100	5 k	25	$\pm 0,1$	71
	B57867 (S 867)	- 55/155	3 k ... 30 k	25	$\pm 1 \text{ %};$ $\pm 3 \text{ %}; \pm 5 \text{ %}$	74
	B57863 (S 863)	- 55/155	3 k ... 30 k	25	$\pm 0,2;$ $\pm 0,5$	75
	B57869 (S 869)	- 55/155	3 k ... 30 k	25	$\pm 0,2;$ $\pm 0,5$	81

NTC thermistors for temperature measurement



Type	T_A °C	R_N Ω	T_N °C	$\Delta R_N/R_N$	Page	
<i>Probe assemblies</i>						
	B57045 (K 45)	- 55/125	1 k ... 150 k	25	± 10 %	82
	B57703 (M 703)	- 55/125	10 k	25	± 2 %	84
	B57276 (K 276)	- 10/100	1704	80	± 2 %	86

Selector Guide

NTC thermistors for temperature measurement



Type	T_A °C	R_N Ω	T_N °C	$\Delta R_N/R_N$	Page
 B57277 (K 277)	- 40/100	2 k	5	± 2,5 %	88
 B57227 (K 227)	- 55/155	1,8 k	100	± 10 %	90
 B57831 (M 831)	- 10/100	359,3 k	50	± 2,5 %	92

NTC thermistors for temperature measurement

Type	T_A °C	R_N Ω	T_N °C	$\Delta R_N/R_N$	Page	
<i>Probe assemblies</i>						
	B57020 (M 2020)	- 40/60	16330	0	-	94
	B57912 (M 912)	- 40/100	9 k	0	± 2 %	95
	B57010 (Z 10)	- 25/100	10 k	25	± 2 %	97

Selector Guide

NTC thermistors for inrush current limiting

Type	T_A °C	R_{25} Ω	P_{25} W	I_{max} A	Page	
	B57153 (S 153)	- 55/170	4,7 ... 33	1,4	1,3 ... 3,0	99
	B57234 (S 234)	- 55/170	1,0 ... 60	3,6	3,3 ... 11,5	100
	B57235 (S 235)	- 55/170	5,0 ... 10,0	1,8	3,0 ... 4,2	101
	B57236 (S 236)	- 55/170	2,5 ... 80	2,1	1,6 ... 5,5	102
	B57237 (S 237)	- 55/170	1,0 ... 33	3,1	2,5 ... 9,0	103
	B57364 (S 364)	- 55/170	1,0 ... 10	5,1	7,5 ... 16,0	104
	B57464 (S 464)	- 55/170	1,0	6,7	20	105

Applications

S+M offers a broad range of NTC thermistors for temperature measurement and inrush current limiting. To facilitate selection of the right thermistor for your application we have compiled the following tables and charts.

Temperature measurement

Temperatures can be determined by point-matching or uni curve NTC thermistors. While point-matching thermistors feature their highest accuracy in a tight range around the rated temperature, uni curve thermistors exhibit a high measuring accuracy over a wide temperature range.

The chart for point-matching thermistors on page [20](#) assigns the different models and their rated resistances R_N to rated temperatures T_N .

With the table below you can select uni curve thermistors by resistance ratings (at 25 °C) and temperature tolerances .

Uni curve NTC thermistors

R_{25}	Temperature tolerance				
	Page				
Ω	$\pm 0,1$ K	$\pm 0,2$ K	$\pm 0,5$ K	± 1 K	± 2 K
2,2 k			63	63	63
3 k		75 81	75 81		
5 k	71	75	75		
10 k		75 81	63 75 81	63	63
20 k			63	63	63
30 k		75 81	75 81		
100 k			63	63	63

Inrush current limiting

NTC thermistors can limit excessive inrush currents effectively and at attractive cost. Fields of application are electric motors, transformers and switch-mode power supplies. The chart on page [22](#) correlates sizes, maximum permissible currents I_{max} and typical NTC resistances R_{25} .

Temperature Measurement Point-Matching NTC Thermistors

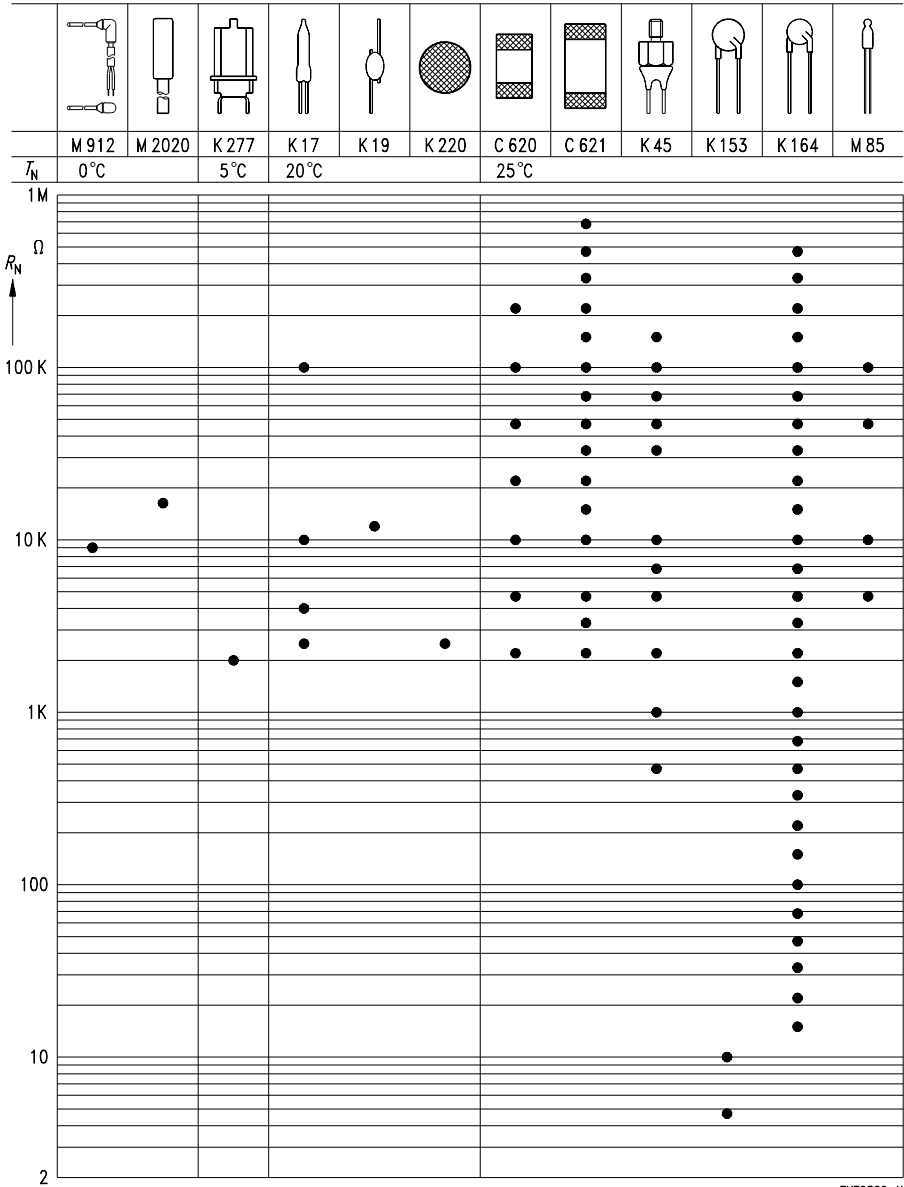

TNT0360-X

Temperature Measurement Point-Matching NTC Thermistors

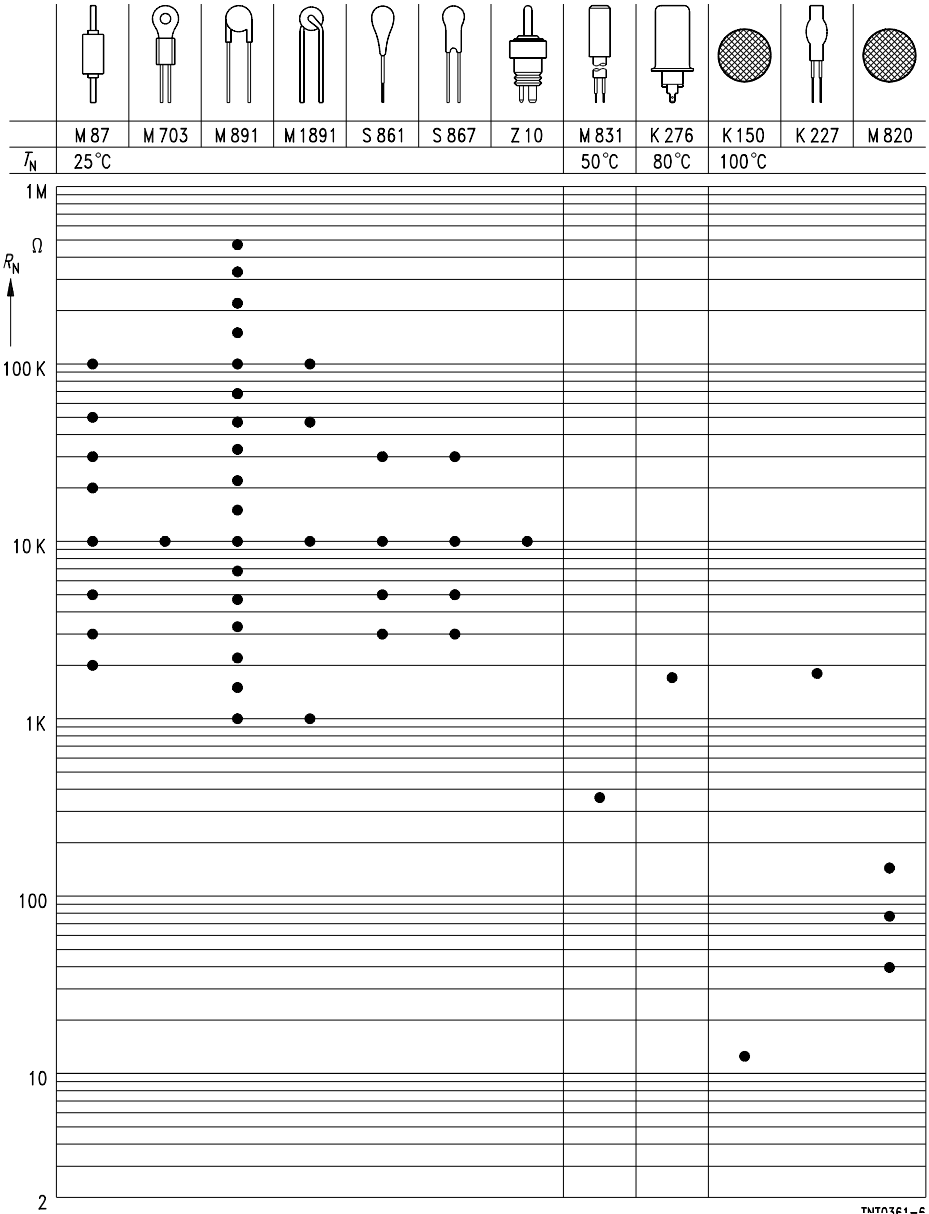

Inrush Current Limiting

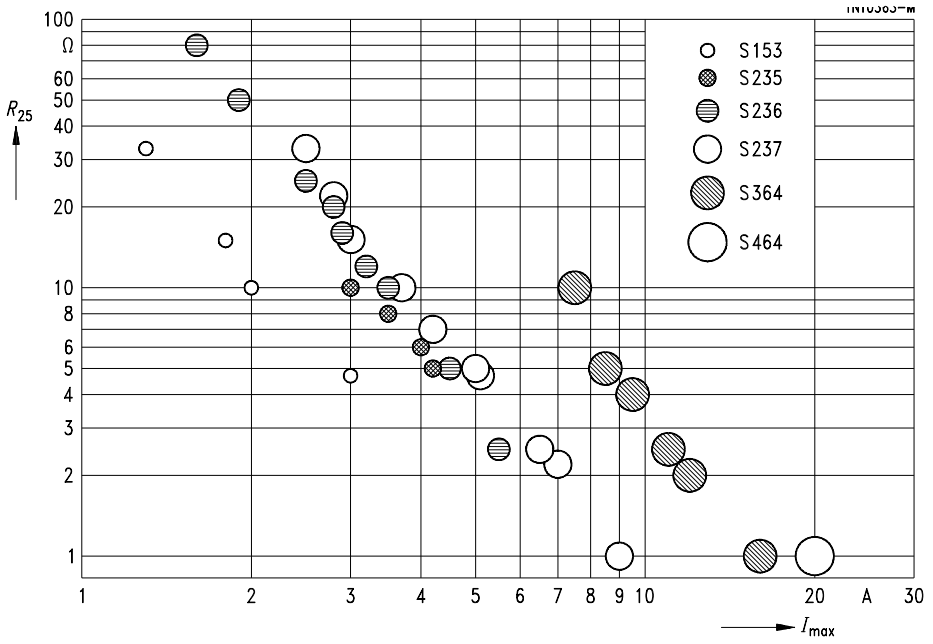

General Technical Information

1 Definition

As defined by IEC 539, CECC 43 000 and DIN 44 070, NTC (Negative Temperature Coefficient) thermistors are thermally sensitive semiconductor resistors which show a decrease in resistance as temperature increases. With $-2\%/K$ to $-6\%/K$, the negative temperature coefficients of resistance are about ten times greater than those of metals.

Changes in the resistance of the NTC thermistor can be brought about either externally by a change in ambient temperature or internally by self-heating resulting from a current flowing through the device. All practical applications are based on this behavior.

NTC thermistors are made of polycrystalline mixed oxide ceramics. The conduction mechanisms in this material are quite complex, i.e. either extrinsic or intrinsic conduction may occur. In many cases NTC thermistors have a spinell structure and then show valence conduction effects.

2 Manufacture

S + M thermistors are produced from carefully selected and tested raw materials. The starting materials are different oxides of metals such as manganese, iron, cobalt, nickel, copper and zinc, to which chemically stabilizing oxides may be added to achieve better reproducibility and stability of the thermistor characteristics.

The oxides are milled to a powdery mass, mixed with a plastic binder and then compressed into the desired shape. Standard shapes are:

Disks: The thermistor material is compressed under very high pressure on pelleting machines to produce round, flat pieces.

Wafers: The ceramic material is compression-molded or drawn and then cut to the required shape.

Beads: The oxide/binder mixture is deposited in the form of small ellipsoids on two fine parallel wires made of platinum alloy.

The blanks are then sintered at high temperatures (between 1000 and 1400 °C) to produce the polycrystalline thermistor body. Disks are contacted by baking a silver paste onto the flat surfaces. With beads the wires embedded in the sintered body serve as contacts. Depending on the application, the thermistors are fitted with leads or tab connectors, coated or additionally incorporated in different kinds of housing. Finally the thermistors are subjected to a special ageing process to ensure high stability of the electrical values. Otherwise the NTC resistance would possibly change even at room temperature due to solid-state reactions in the polycrystalline material.

A flow chart in the quality section of this book ([see page 145](#)) shows the individual processing steps in detail. The chart also illustrates the extensive quality assurance measures taken during manufacture to guarantee the constantly high quality level of our thermistors.

3 Characteristics

A current flowing through a thermistor may cause sufficient heating to raise the thermistor's temperature above the ambient. As the effects of self-heating are not always negligible (or may even be intended), a distinction has to be made between the characteristics of an electrically loaded thermistor and those of an unloaded thermistor. The properties of an unloaded thermistor are also termed "zero-power characteristics".

General Technical Information

3.1 Unloaded NTC thermistors

3.1.1 Temperature dependence of resistance

The dependence of the resistance on temperature can be approximated by the following equation:

$$R_T = R_N \cdot e^{B \cdot \left(\frac{1}{T} - \frac{1}{T_N} \right)} \quad (1)$$

R_T NTC resistance in Ω at temperature T in K

R_N NTC resistance in Ω at rated temperature T_N in K

T, T_N Temperature in K

B B value, material-specific constant of the NTC thermistor

e Base of natural logarithm ($e = 2,71828$)

The actual characteristic of an NTC thermistor can, however, only be roughly described by the exponential relation, as the material parameter B in reality also depends on temperature. So this approach is only suitable for describing a restricted range around the rated temperature or resistance with sufficient accuracy.

For practical applications a more precise description of the real R/T curve is required. Either more complicated approaches (e.g the Steinhart-Hart equation) are used or the resistance/temperature relation is given in tabulated form. Subsequent to the data sheet section you will find tables for real R/T curves (page 110 ff). These standardized curves have been experimentally determined with utmost accuracy; they are also available for temperature increments of 1 degree.

3.1.2 B value

As already mentioned in the paragraph above, the B value depends on temperature. Thus it is important to know to which temperature B is referred. The specifications in this data book refer to measurement at temperatures of 25 °C (T_1) and 100 °C (T_2). Symbol: $B_{25/100}$.

The B value for a particular NTC thermistor can be determined by measuring the resistance at 25 °C (R_1) and 100 °C (R_2) and inserting these resistance values into the following equation:

$$B = \frac{T_1 \cdot T_2}{T_2 - T_1} \cdot \ln \frac{R_1}{R_2} = \frac{(25 + 273,15) \cdot (100 + 273,15)}{75} \cdot \ln \frac{R_{25}}{R_{100}} = 1483,4 \cdot \ln \frac{R_{25}}{R_{100}} \quad (2)$$

The B values for common NTC materials range from 2000 through 6000 K. Figure 1 illustrates the dependence of the R/T characteristic on the B value.

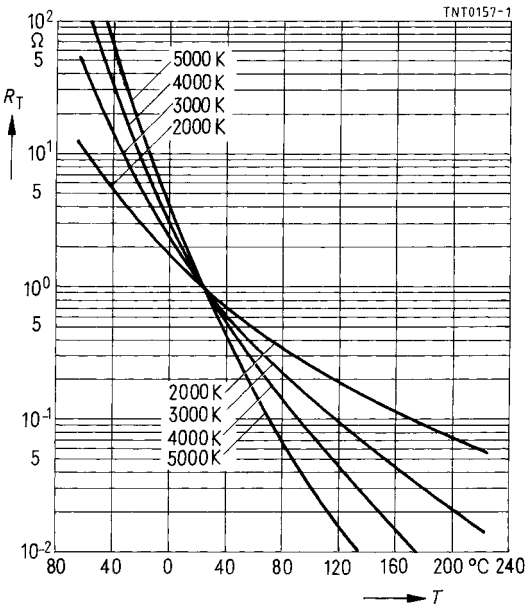

Figure 1
Resistance/temperature characteristics
(Parameter: B value)

3.1.3 Tolerance

The rated resistance R_N and the B value are subject to manufacturing tolerances. Due to this tolerance of the B value, an increase in resistance spread must be expected for temperatures that lie above or below the rated temperature T_N .

With regard to the tolerance of resistance a distinction is made between two basic types of NTC thermistor:

a) Point-matching NTC thermistors

With point-matching NTC thermistors a particular resistance tolerance is specified for one temperature point, which is usually 25 $^{\circ}\text{C}$. In principle, NTC thermistors can also be point-matched to other temperatures than those specified in the data sheets (upon customer request). Point-matching NTC thermistors are ideal for applications where exact measurements are to be performed within a tight range around the rated values. Example: refrigerator sensor at 5 $^{\circ}\text{C}$ (K277).

b) Uni curve NTC thermistors

Uni curve NTC thermistors are used when a high measuring accuracy is required over a wide temperature range ($T_1 \dots T_2$). For this kind of application we offer several standard types for which measuring accuracies between 0,2 and 2 K (depending on requirements) can be guaranteed over a temperature range of 0 through 70 $^{\circ}\text{C}$. Thus only one NTC thermistor is required to measure different temperatures with the same accuracy. Uni curve thermistors are available as mini-sensors (S 861, S863, S867, S869) and as leaded disks (S891).

Typical curves for the temperature tolerances of point-matching and uni curve thermistors

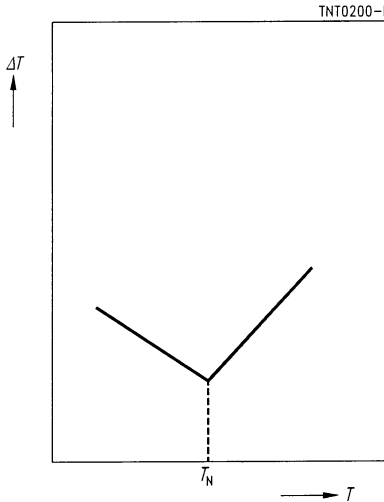

Figure 2a
Point-matching NTC thermistors

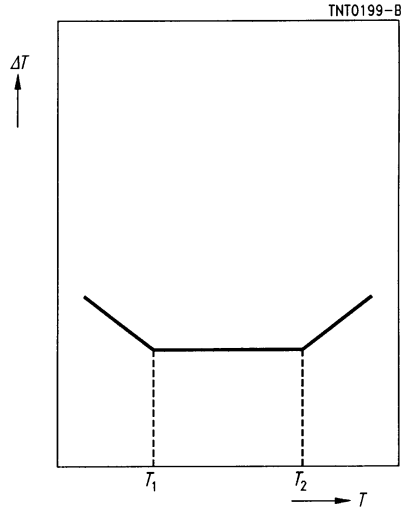

Figure 2b
Uni curve NTC thermistors

Generally, the resistance tolerance can be expressed by the following relation:

$$\Delta R_T = \left| \frac{\partial R(T)}{\partial R_N} \right| \cdot \Delta R_N + \left| \frac{\partial R(T)}{\partial B} \right| \cdot \Delta B + \left| \frac{\partial R(T)}{\partial T} \right| \cdot \Delta T \quad (3)$$

If the third temperature-dependent term in (3) is neglected, the equation can be simplified as follows:

$$\left| \frac{\Delta R_T}{R_T} \right| = \left| \frac{\Delta R_N}{R_N} \right| + \left| \frac{\Delta R_B}{R_T} \right| \quad (4)$$

In this formula ΔR_B denotes the resistance tolerance resulting from the spread of the B value.

As can be seen from the equation, the resistance tolerance at a certain temperature is influenced by two variables: the manufacturing tolerance of the rated resistance and the variation of the B value with temperature.

For a practical estimate of resistance and temperature tolerances please refer to the resistance/tolerance tables ().

3.1.4 Temperature coefficient α

The temperature coefficient of resistance is defined as the relative change in resistance referred to the change in temperature.

$$\alpha = \frac{1}{R} \cdot \frac{dR}{dT} \quad (5)$$

By means of this equation resistance and temperature tolerances can be calculated for small temperature intervals.

$$\Delta T = \frac{1}{\alpha \cdot R} \cdot \Delta R \quad \Delta R = \alpha \cdot R \cdot \Delta T \quad (6)$$

For practical application we recommend that the standardized R/T curves (see page 107 ff) are used; the temperature steps tabulated there are small enough to permit calculation by the approximation formulae given above.

3.1.5 Zero-power measurement

The zero-power resistance is the resistance value measured at a given temperature T with the electrical load kept so small that there is no noticeable change in the resistance value if the load is further decreased. At too high a measuring load the test results will be distorted by the self-heating effect (see 3.2). When a low-resistance NTC thermistor is to be measured, the resistance of the measuring lines must be taken into account.

Example: For S861, $R_{25} = 10 \text{ k}\Omega$ the measuring current I_{Meas} is $\leq 100 \text{ }\mu\text{A}$.

3.2 Electrically loaded NTC thermistors

When a current flows through the thermistor, the device will heat up more or less by power dissipation. This self-heating effect depends not only on the load applied, but also on the thermal dissipation factor δ and the geometry of the thermistor itself.

The general rule is:

The smaller the device, the smaller is the permissible maximum load and the measuring load (zero power).

General Technical Information

The following general rule applies to self-heating of an NTC thermistor by an electrical load:

$$P = V \cdot I = \frac{dH}{dt} = \delta_{th} \cdot (T - T_A) + C_{th} \cdot \frac{dT}{dt} \quad (7)$$

P	Electrical power applied
V	Instantaneous value of NTC voltage
I	Instantaneous value of NTC current
dH/dt	Change of stored thermal energy with time
δ	Dissipation factor of NTC thermistor
T	Instantaneous temperature of NTC thermistor
T_A	Ambient temperature
C_{th}	Heat capacity of NTC thermistor
dT/dt	Change of temperature with time

3.2.1 Voltage/current characteristic

If a constant electrical power is applied to the thermistor, its temperature will first increase considerably, but this change declines with time. After some time a steady state will be reached where the power is dissipated by thermal conduction or convection.

In case of thermal equilibrium dT/dt equals 0 and thus one obtains

$$V \cdot I = \delta_{th} \cdot (T - T_A) \quad (8)$$

and with $V = R \cdot I$:

$$I = \sqrt{\frac{\delta_{th} \cdot (T - T_A)}{R(T)}} \quad (9a)$$

or

$$V = \sqrt{\delta_{th} \cdot (T - T_A) \cdot R(T)} \quad (9b)$$

This is the so-called parametric description of the voltage/current curve with $R(T)$ being the temperature-dependent NTC resistance. With the aid of the above equations these curves can be calculated for different ambient temperatures.

By plotting the voltage values obtained at constant temperature as a function of current one gets the voltage/current characteristic of the NTC thermistor.

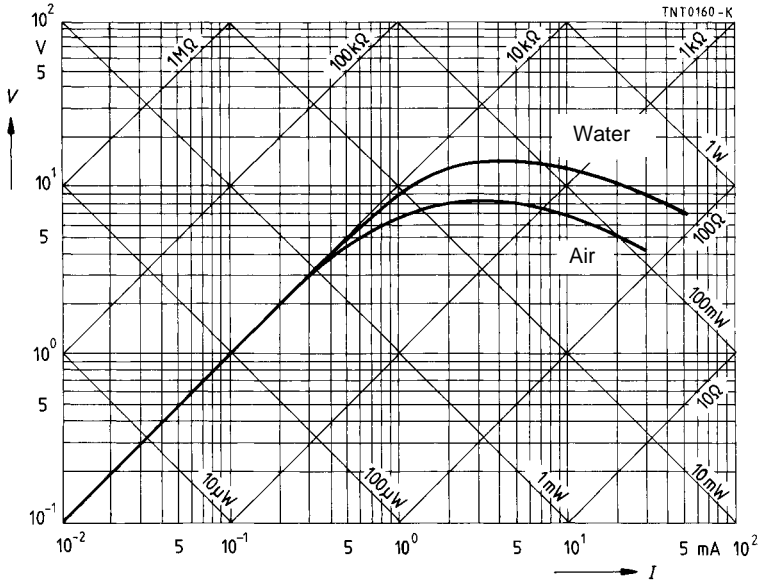

Figure 3
Current/voltage characteristic

Measurement at constant ambient temperature, still air

On a log-log scale the curves for constant power and constant resistance take the shape of a straight line.

The voltage/current characteristic of an NTC thermistor has three different sections:

1. The section of straight rise where the dissipation power only produces negligible self-heating. Voltage and current are proportional to each other and follow Ohm's law. The resistance value is exclusively determined by the ambient temperature. Use of this curve section is made when NTC thermistors are employed as temperature sensors.

$$(dV/dI = R = \text{constant})$$

2. The section of non-linear rise up to maximum voltage where resistance already begins to drop. At maximum voltage the relative decrease in resistance $\Delta R/R$ resulting from self-heating is equal to the relative increase in current $\Delta I/I$.

$$(R > dV/dI \geq 0)$$

3. The falling-edge section where the decrease in resistance is greater than the relative increase in current.

$$(dV/dI \leq 0)$$

General Technical Information

3.2.2 Behavior in different media

As shown by equations (9a) and (9b) the voltage/current curve is influenced not only by the NTC resistance $R(T)$ but also by the dissipation factor δ_{th} . The dissipation factor, in turn, depends on size, shape and leads of the device as well as on the medium surrounding the thermistor.

The voltage/current curves specified in the data sheets apply to still air. In stirred air or in a liquid the dissipation factor increases and the V/I curve shifts towards higher values of voltage and current. The opposite applies when the thermistor is suspended in a vacuum.

The voltage/current curve thus indicates by which medium the thermistor is surrounded. This means that NTC thermistors can be used for sensing the flow rate of gases or liquids, for vacuum measurement or for gas analysis.

3.2.3 Maximum power rating P

P is the maximum power an NTC thermistor is capable of handling at a particular ambient temperature with its own temperature not exceeding the maximum category temperature. In addition to the ambient temperature, mainly the dissipation factor δ_{th} determines the power handling capability.

With known dissipation factor δ_{th} the maximum power handling capability can be calculated by:

$$P_{max} = \delta_{th} (T_{max} - T_A) \quad (10)$$

3.2.4 Dissipation factor δ_{th}

The dissipation factor δ_{th} is defined as the ratio of the change in power dissipation and the resultant change in the thermistor's body temperature. It is expressed in mW/K and serves as a measure for the load which causes a thermistor in steady state to raise its body temperature by 1 K. The higher the dissipation factor, the more heat is dissipated by the thermistor to the environment.

$$\delta_{th} = dP/dT \quad (11)$$

For measuring δ_{th} the thermistor is loaded such that the ratio V/I corresponds to the resistance value measured at $T_2 = 85^\circ\text{C}$.

$$\delta_{th} = \frac{V \cdot I}{T_2 - T_1} = \frac{P}{T_2 - T_1} \quad (12)$$

T_2 Body temperature of the NTC thermistor (85°C)

T_1 Ambient temperature

3.2.5 Heat capacity C_{th}

The heat capacity C_{th} is a measure for the amount of heat required to raise the NTC's mean temperature by 1 K. C_{th} is stated in mJ/K.

$$C_{th} = \frac{\Delta H}{\Delta T} \quad (13)$$

The relationship between heat capacity, dissipation factor and thermal time constant is expressed by:

$$C_{th} = \delta_{th} \cdot \tau_{th} \quad (14)$$

3.2.6 Thermal cooling time constant τ_c

The thermal cooling time constant refers to the time necessary for an unloaded thermistor to vary its temperature by 63,2% of the difference between its mean temperature and the ambient temperature.

τ_c depends to a large extent on the component design. The values of τ_c specified in this data book have been determined in still air at an ambient temperature of 25 °C.

The NTC thermistor is internally heated to 85 °C to measure subsequently the time it requires to cool down to 47,1 °C at an ambient temperature of 25 °C. This adjustment to the ambient is asymptotic and occurs all the faster, the smaller the device is.

3.2.7 Thermal time constant τ_a

The thermal time constant refers to the time it takes an unloaded thermistor to raise its body temperature from 25 °C to 62,9 °C when it is immersed in a medium having a temperature of 85 °C. Equally to thermal cooling time constant, τ_a depends on the medium surrounding the device. The medium used for measuring τ_a (e.g. water) is specified in the data sheets.

Determining the thermal time constant:

- a) The zero-power-resistance is measured at 25 °C.
The zero-power resistance is measured at 62,9 °C.
- b) The NTC thermistor is immersed in a liquid bath with a temperature of $(25 \pm 0,1)$ °C until it has assumed the same temperature as the liquid.
- c) The NTC thermistor is then immediately transferred into a second bath with a temperature of $(85 \pm 0,1)$ °C. Subsequently the time is measured it takes the thermistor to reach again the zero-power resistance measured under a) for 62,9 °C.

The resulting time is the thermal time constant for an *external* temperature change.

3.2.8 Ageing and stability

At room temperature the polycrystalline material NTC thermistors are made of shows solid-state reactions which lead to an irreversible change in the characteristics (usually resistance increase, change of *B* value etc).

Physical reasons for this may be thermal stress causing a change in concentration of lattice imperfections, oxygen exchange with the environment (with unprotected, non-glass-encapsulated thermistors) or diffusion in the contact areas of metallized surface contacts. At low temperatures these reactions slow down, but at high temperatures they accelerate and finally decline with time. To enhance long-term stability, our NTC thermistors are subjected to an ageing process directly after manufacture.

4 Application notes

4.1 Applications utilizing the influence of ambient temperature on resistance (self-heating negligible!)

4.1.1 Temperature measurement

The high sensitivity of an NTC thermistor makes it an ideal candidate for temperature sensing applications. These low-cost NTC sensors are usually employed for a temperature range of -40 to $+300$ °C.

Selection criteria for NTC thermistors are

- temperature range
- resistance range
- measuring accuracy
- environment (surrounding medium)
- response time
- dimensional requirements.

One of the circuits suitable for temperature measurement is a Wheatstone bridge with an NTC thermistor used as one bridge leg.

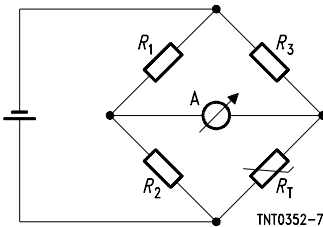

Figure 4
Wheatstone bridge circuit

With the bridge being balanced, any change in temperature will cause a resistance change in the thermistor and a significant current will flow through the ammeter. It is also possible to use a variable resistor R_3 and to derive the temperature from its resistance value (in balanced condition).

4.1.2 Linearizing the R/T characteristic

NTC thermistors exhibit a distinctly non-linear R/T characteristic. If a fairly linear curve is required for measurements over a (wide) temperature range, e.g. for a scale, series-connected or paralleled resistors are quite useful. The temperature range to be covered should, however, not exceed 50 to 100 K.

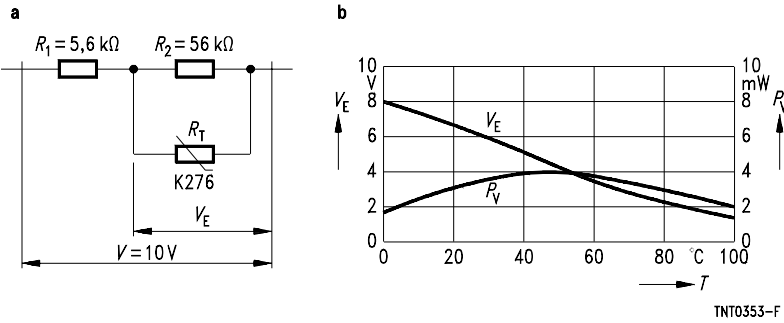

Figure 5

Linearization of the K276/12k NTC thermistor by a paralleled resistor (a). Signal voltage and power dissipation curves of the linearized NTC thermistor (b).

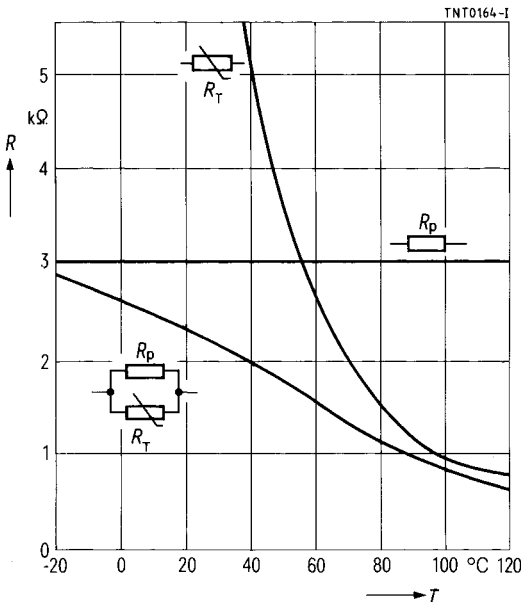

Figure 6

Resistance/temperature characteristic linearized by a paralleled resistor

The combination of an NTC thermistor and a paralleled resistor has an S-shaped R/T characteristic with a turning point. The best linearization is obtained by laying the turning point in the middle of the operating temperature range. The resistance of the paralleled resistor can then be calculated by the exponential approximation:

$$R_p = R_{TM} \cdot \frac{B - 2T_M}{B + 2T_M}$$

General Technical Information

The total resistance of $R_T \parallel R_p$ is:

$$R = \frac{R_p \cdot R_T}{R_p + R_T}$$

R_{TM} Resistance value of the NTC thermistor at mean temperature T_M
(in $K \equiv \text{temperature in } ^\circ\text{C} + 273,15$)

B B value of the NTC thermistor

The rate of rise of the (linearized) R/T characteristic is:

$$\frac{dR}{dT} = - \frac{R_T}{\left(1 + \frac{R_T}{R_p}\right)^2} \cdot \frac{B}{T^2}$$

The circuit sensitivity however decreases with linearization.

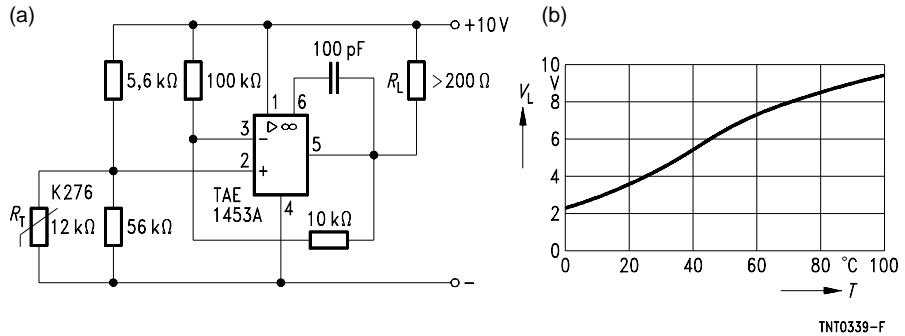

Figure 7

Linearization of the R/T characteristic

a) simple amplifier circuit

b) output voltage at the load resistor as a function of temperature

4.1.3 Temperature compensation

Virtually all semiconductors and the circuits comprised of them exhibit a temperature coefficient. Owing to their high positive temperature coefficient, NTC thermistors are particularly suitable for compensating this undesired response to temperature changes (examples: working point stabilization of power transistors, brightness control of LC displays). Resistors in series or shunt plus suitable voltage dividers and bridge circuits provide an excellent and easy-to-implement compensation network.

It is important to match the temperature of the compensating NTC thermistor to that of the component causing the temperature response. Temperature-compensating thermistors are therefore not only available in conventional leaded styles, but also incorporated in screw-type housings for attachment to heat sinks and as chip version for surface mounting.

Figure 8 shows a simple circuit configuration for a thermostat.

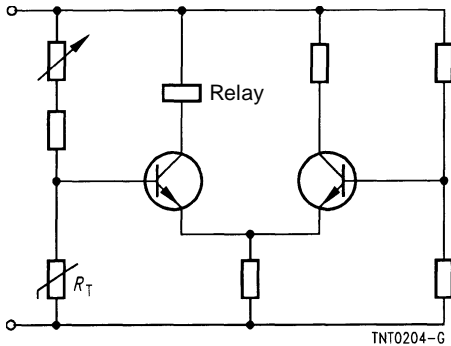

Figure 8

Circuit for a temperature controller

NTC thermistors for temperature measurement are suitable for a large variety of applications

- in household electronics: in refrigerators and deep freezers, washing machines, electric cookers, hair-driers, etc.
- in automotive electronics: for measuring the temperature of cooling water or oil, for monitoring the temperature of exhaust gas, cylinder head or braking system, for controlling the temperature in the passenger compartment, ...
- in heating and air conditioning: in heating cost distributors, for room temperature monitoring, in underfloor heating and gas boilers, for determining exhaust gas or burner temperature, as outdoor temperature sensors, ...
- in industrial electronics: for temperature stabilization of laser diodes and photoelements, for temperature compensation in copper coils or reference point compensation in thermoelements, etc.

4.2 Applications utilizing the non-linear voltage/current characteristic (in self-heated mode)

4.2.1 Inrush current limiting

Many items of equipment like switch-mode power supplies, electric motors or transformers exhibit excessive inrush currents when they are turned on, meaning that other components may be damaged or fuses may be tripped. With NTC thermistors it is possible to effectively limit these currents, at attractive cost, by connecting a thermistor in series with the load.

The NTC thermistors specially developed for this application limit the current at turn-on by their relatively high cold resistance. As a result of the current load the thermistor heats up and reduces its resistance by a factor of 10 to 50; the power it draws reduces accordingly.

General Technical Information

NTC thermistors are able to effectively handle higher inrush currents than fixed resistors with the same power consumption.

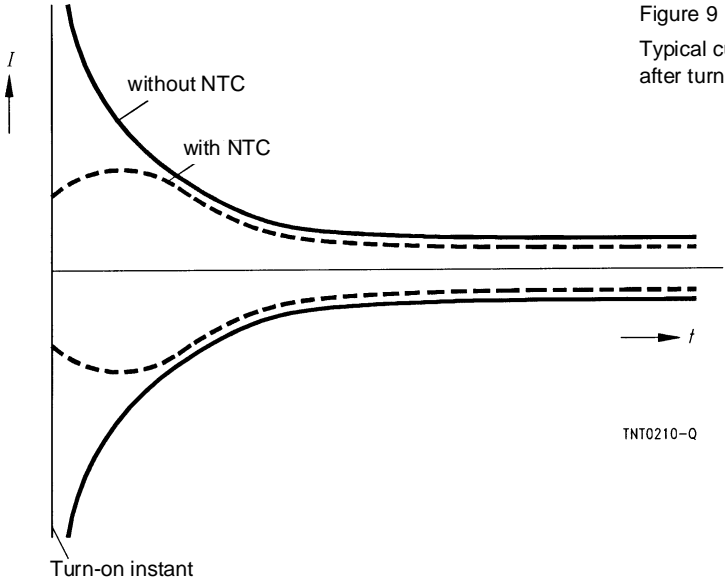

Figure 9
Typical current curve of a load after turn-on (envelope curve)

The NTC thermistor thus provides protection from undesirably high inrush currents, while its resistance remains negligibly low during continuous operation.

4.2.2 Series and parallel connection

An NTC thermistor is always connected in series with the load to be protected. If the inrush current cannot be handled by one thermistor alone, two or more thermistor elements can be connected in series. Paralleling several NTC thermistors is inadmissible, since the load will not be evenly distributed. The thermistor carrying the largest portion of current will heat up until it finally receives the entire current (which may result in destruction of the device), while the other paralleled thermistors remain cold.

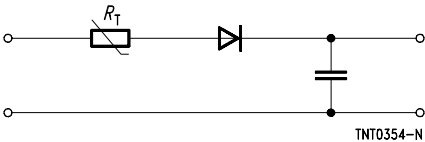

Figure 10
Basic circuit diagram for diode protection

Figure 11 shows a typical example of an inrush protection circuit:

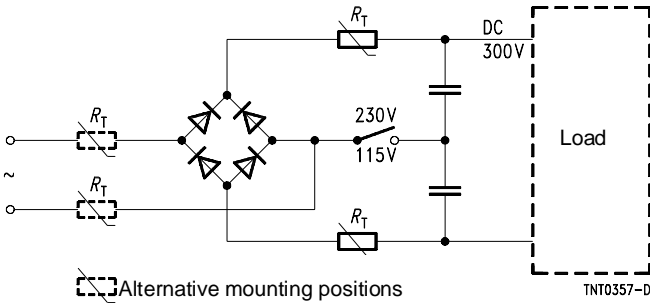

Figure 11

Mounting positions for NTC thermistors in a protective circuit

Selection of the most appropriate NTC thermistor is the precondition for effective circuit protection. The first and most important criterion is the maximum current during continuous operation, which is determined by the load. The rated resistance of the thermistor results from this current value.

4.2.3 Self-heating

The self-heating of a thermistor during operation depends on the load applied. Although some heat is being dissipated, the NTC thermistor may in extreme cases reach a mean temperature of up to 250 °C. The dissipation factor δ_{th} specified in the data sheets has been measured in still air at $T_A = 25$ °C on devices with clamp contacts. A change in the measuring conditions (e.g. stirred air = blower increases the dissipation factor) will influence the dissipation factor.

The heat developed during operation will also be dissipated through the lead wires. When mounting NTC thermistors it should therefore be considered that the contact areas may become quite hot at maximum load.

General Technical Information

4.2.4 Load derating

The power handling capability of an NTC thermistor cannot be fully utilized over the entire temperature range. For circuit dimensioning the derating curve given below provides information on the extent to which the current must be reduced at a certain ambient temperature.

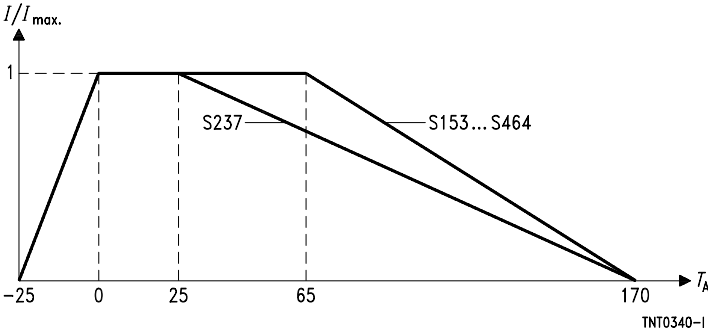

Figure 12
Derating curve

The I_{max} values specified in the data sheets denote the maximum permissible continuous current (dc or rms values for sine-shaped ac) in the temperature range 0 °C to 65 °C.

4.2.5 Restart

When the load has been switched off the thermistor slowly cools down. Its resistance increases steadily, but the full resistance value is only reached after 1 to 2 minutes (depending on ambient temperature and type).

It may therefore be useful in some applications to bypass the thermistor during restart. Operation can thus be faster resumed and system performance will not be affected by the thermistor.

4.2.6 Dependence of NTC resistance on current

The resistance effective in the usual current range can be approximated as follows:

$$R_{NTC} = k \cdot I^n \qquad 0,3 \cdot I_{max} < I \leq I_{max}$$

- R_{NTC} Resistance value to be determined at current I [Ω]
- k, n Fit parameter, see individual data sheets
- I Current flowing through the NTC (insert numerical value in A)

The calculated values only serve as an estimate for operation in still air at an ambient temperature of 25 °C.

Note: With the equation above sufficiently accurate results are only obtained for the limited current range stated above.

4.2.7 Pulse strength

The currents during turn-on are much higher than the rated currents during continuous operation. To test the effects of these current surges S+M uses the following standard procedure:

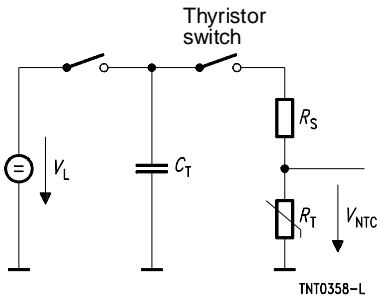

Figure 13

Test circuit for evaluating the pulse strength of an NTC thermistor

V_L	Load voltage [V]
C_T	Test capacitance [μF]
R_S	Series resistance [$R_S = 1 \Omega$]
V_{NTC}	Voltage drop across the NTC under test [V]

In the pulse test the capacitor C_T is discharged via the series resistor R_S and the NTC thermistor. The load voltage is chosen such that the voltage applied to the thermistor at the start of discharge is $V_{NTC} = 345 \text{ V}$ (corresponds to $(230 \text{ V} + \Delta V) \times \sqrt{2}$).

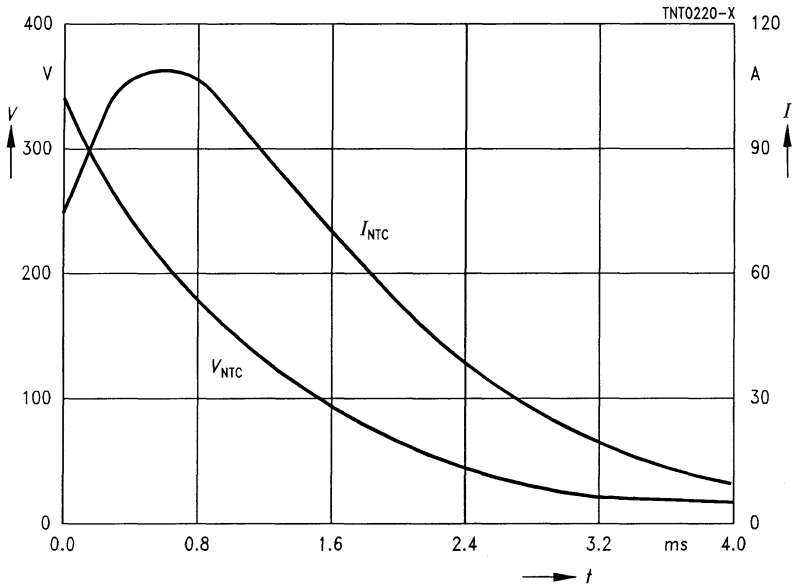

Figure 14
Pulse strength test : typical curves

The maximum capacitances that can be switched depend on the individual thermistor type and are given in the data sheets.

4.2.8 Applications

Inrush current limiters are primarily used in industrial electronics and equipment engineering. Application examples are:

Inrush current limiting in fluorescent, projector and halogen lamps, rotational speed limiting in kitchen machines, soft start of motors and switch-mode power supplies etc.

S+M thermistors are available in a variety of sizes and rated resistances to optimally match your application. The product line ranges from the small-size S153 with a maximum power of 1.4 W through to the at present largest S464 with a maximum power of 6,7 W. Maximum continuous ac currents of 20 A are reached. Inrush current limiters are presented on pages 99 to 105.

4.3 Applications utilizing the influence of the dissipation factor on the voltage/current characteristic

4.3.1 Liquid level sensors

The temperature of an electrically loaded NTC thermistor depends on the medium surrounding the device. When the thermistor is immersed in a liquid the dissipation factor increases, the temperature decreases and the voltage lying across the NTC rises. Owing to this effect NTC thermistors are able to sense the presence or absence of a liquid.

Glass-encapsulated beads are particularly suitable for level sensing. On the one hand the glass coat protects the thermistor from the liquid to be monitored, and on the other hand it is thin enough to ensure good thermal contact.

Examples of suitable types: K17, M85.

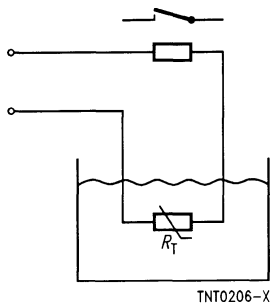

Figure 15

Circuit for liquid level sensing

4.3.2 Flow rate and vacuum measurement

Here too, the thermistor is operated by means of an electrical load. Its temperature and resistance are influenced by the surrounding medium. Stirred air lowers the NTC's temperature and thus increases its resistance. A vacuum, in contrast, increases the NTC's temperature and thus causes a decrease in resistance. Hence NTC thermistors can be used to monitor ventilators, to measure the flow rate of gases or for vacuum measurement.

Examples of suitable types K17, K19.

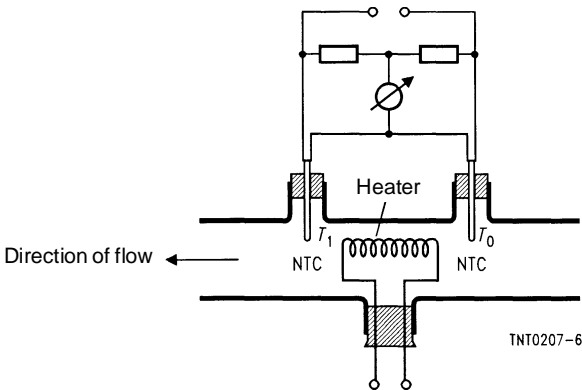

Figure 16

Experimental circuit for flow rate measurement

Application examples are found in

- physics and chemistry: level control of various liquids, as for example liquid nitrogen, measurement of the thermal conductivity or flow rate of gases, vacuum and radiation measurement
 - in automotive electronics for tank content indication
- etc.

4.4 Applications utilizing the current/time characteristic

If an NTC thermistor is connected to a voltage source via a series resistor and the current is measured as a function of time, an increase in current will be observed.

At first the thermistor is cold, i.e. in high-resistance mode, and only a low current is flowing through the device. But this current starts to heat up the thermistor and the wattage increases with the resistance value of the thermistor approaching that of the series resistor. Thus the increase in current becomes faster and faster till the two resistance values are equal. With further decreasing NTC resistance the wattage will also decrease due to the growing mismatch and the current reaches a final value. The entire wattage is consumed in maintaining the overtemperature.

Relay delay

To delay relay pick-up thermistor and relay are connected in series. When applying a voltage V_{op} the current flowing through the relay coil is limited to a fraction of the pick-up current by the high cold resistance of the thermistor. With the thermistor heating up, its resistance decreases and the current rises until the pick-up value is reached.

To delay relay drop-out relay and thermistor are connected in parallel.

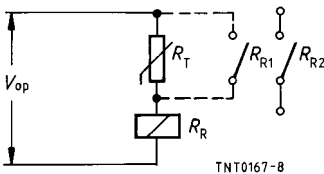

Figure 17
Delay of relay pick-up

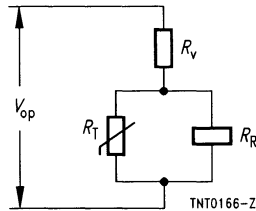

Figure 18
Delay of relay drop-out

The operating sequence of a relay delayed by a thermistor depends on the recovery time of the thermistor. The thermistor has to cool down before it can cause second delay. If the thermistor remains unloaded for a time $t = 3 \cdot \tau_{th}$ (3 times the thermal cooling time constant) between two operations, the time for the second delay will be 80 % to 90 % of that for the first delay. It is therefore useful to short-circuit or switch off the thermistor by additional relay contacts, so that the thermistor has sufficient time to cool down (see dashed section in figure 17).



Siemens Matsushita Components

EMI suppression capacitors

Play it safe

Whether video recorder, television, refrigerator or toaster – our EMI suppression capacitors do a grand job in every possible kind of entertainment and consumer electronics appliance. They've also proven their worth in switch-mode power supplies for PCs. No wonder, because the advantages of film technology are there to be seen: low cost, no risk of failure through damp, and optimum self-



healing capability. The result – less destruction of equipment and ensuing fires. Plus the line is safeguarded against surges. In this way our capacitors satisfy the user's need for safety, and the new EMC standards too of course.

SCS – dependable, fast and competent



Applications

- Temperature compensation
- Hybrid circuits
- Data systems
- Telecom systems
- Automotive electronics
- Crystal oscillators
- LC displays

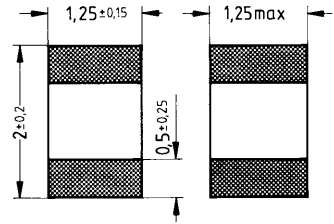

Termination TNT0033-H

Dimensions in mm
Approx. weight 13 mg

Features

- Small dimensions, EIA size 0805
- Silver palladium terminations
- Cost-effective
- Suitable for automatic placement
- Suitable for wave and reflow soldering
- Available on tape (PU: 4000 pcs)

Options

Alternative resistance ratings and tolerance < 5% available on request

Climatic category (IEC 68-1)		55/125/21	
Max. power at 25 °C (on PCB)	P_{25}	210	mW
Resistance tolerance	$\Delta R/R_N$	$\pm 5\%$, $\pm 10\%$, $\pm 20\%$	
Rated temperature	T_N	25	°C
B value tolerance	$\Delta B/B$	$\pm 3\%$	
Dissipation factor (on PCB)	$\delta_{th}^{(1)}$	approx. 3,5	mW/K
Thermal cooling time constant (on PCB)	$\tau_c^{(1)}$	approx. 10	s
Heat capacity	$C_{th}^{(1)}$	approx. 35	mJ/K

Type	R_{25} Ω	No. of R/T characteristic	$B_{25/100}$ K	Ordering code
C 620/2,2 k/+	2,2 k	1304	3300	B57620-C222+62
C 620/4,7 k/+	4,7 k	1307	3560	B57620-C472+62
C 620/10 k/+	10 k	1011	3730	B57620-C103+62
C 620/22 k/+	22 k	2003	3980	B57620-C223+62
C 620/47 k/+	47 k	2101	4100	B57620-C473+62
C 620/100 k/+	100 k	2004	4100	B57620-C104+62
C 620/220 k/+	220 k	2904	4300	B57620-C224+62

- + : J for $\Delta R/R_N = \pm 5\%$
- K for $\Delta R/R_N = \pm 10\%$
- M for $\Delta R/R_N = \pm 20\%$

1) Depends on mounting situation

Reliability data

Tested on standardized PCB in accordance with DIN draft 45 924

Test	Standard	Test conditions	$\Delta R_{25}/R_{25}$ (typical)	Remarks
Storage in dry heat	IEC 68-2-2	Storage at upper category temperature T: 125 °C t: 1000 h	< 3 %	
Storage in damp heat, steady state	IEC 68-2-3	Temperature of air: 40 °C Relative humidity of air: 93 % Duration: 21 days	< 3 %	No visible damage
Rapid temperature cycling	IEC 68-2-14	Lower test temperature: -55 °C Upper test temperature: 125 °C Number of cycles: 10	< 3 %	
Endurance	DIN draft 45 924	P_{max} : 210 mW Duration: 1000 h	< 5 %	
Solderability	IEC 68-2-58	Solderability: 215 °C/4 s 235 °C/2 s Resistance to soldering heat: 260 °C/10 s	< 5 %	95 % of terminations wetted
Robustness of terminations	DIN draft 45 924	Bending of carrier (2 mm bending)	< 5 %	No visible damage

Applications

- Temperature compensation
- Hybrid circuits
- Data systems
- Telecom systems
- Automotive electronics
- LC displays

Features

- Small dimensions, EIA size 1206
- Silver palladium terminations
- Cost-effective
- Suitable for automatic placement
- Suitable for wave and reflow soldering
- Available on tape (PU: 4000 pcs)

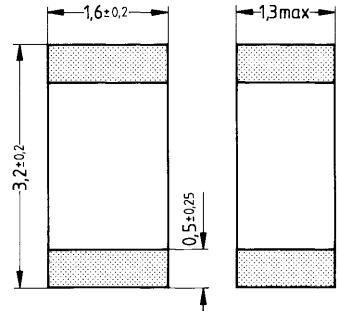

Termination

TNT0034-0

Dimensions in mm
Approx. weight 18 mg

Options

Alternative resistance ratings and tolerance < 5% available on request

Climatic category (IEC 68-1)		55/125/21	
Max. power at 25 °C (on PCB)	P_{25}	300	mW
Resistance tolerance	$\Delta R/R_N$	± 5 %, ± 10 %, ± 20 %	
Rated temperature	T_N	25	°C
B value tolerance	$\Delta B/B$	± 3 %	
Dissipation factor (on PCB)	$\delta_{th}^{1)}$	approx. 5	mW/K
Thermal cooling time constant (on PCB)	$\tau_c^{1)}$	approx. 10	s
Heat capacity	$C_{th}^{1)}$	approx. 50	mJ/K

Type	R_{25} Ω	No. of R/T characteristic	$B_{25/100}$ K	Ordering code
C 621/2,2 k/+	2,2 k	1308	3060	B57621-C222+62
C 621/3,3 k/+	3,3 k	1309	3520	B57621-C332+62
C 621/4,7 k/+	4,7 k	1309	3520	B57621-C472+62
C 621/10 k/+	10 k	1010	3530	B57621-C103+62
C 621/15 k/+	15 k	1008	3560	B57621-C153+62
C 621/22 k/+	22 k	1008	3560	B57621-C223+62
C 621/33 k/+	33 k	2003	3980	B57621-C333+62
C 621/47 k/+	47 k	2001	3920	B57621-C473+62
C 621/68 k/+	68 k	2001	3920	B57621-C683+62

1) Depends on mounting situation

Type	R_{25} Ω	No. of R/T characteristic	$B_{25/100}$ K	Ordering code
C 621/100 k/+	100 k	4901	3950	B57621-C104+62
C 621/150 k/+	150 k	2004	4100	B57621-C154+62
C 621/220 k/+	220 k	2903	4200	B57621-C224+62
C 621/330 k/+	330 k	1014	4250	B57621-C334+62
C 621/470 k/+	470 k	1014	4250	B57621-C474+62
C 621/680 k/+	680 k	4002	4250	B57621-C684+62

+: J for $\Delta R/R_N = \pm 5\%$
 K for $\Delta R/R_N = \pm 10\%$
 M for $\Delta R/R_N = \pm 20\%$

Reliability data

Tested on standardized PCB in accordance with DIN draft 45 924

Test	Standard	Test conditions	$\Delta R_{25}/R_{25}$ (typical)	Remarks
Storage in dry heat	IEC 68-2-2	Storage at upper category temperature $T: 125\text{ }^\circ\text{C}$ $t: 1000\text{ h}$	< 3 %	
Storage in damp heat, steady state	IEC 68-2-3	Temperature of air: $40\text{ }^\circ\text{C}$ Relative humidity of air: 93 % Duration: 21 days	< 3 %	No visible damage
Rapid temperature cycling	IEC 68-2-14	Lower test temperature: $-55\text{ }^\circ\text{C}$ Upper test temperature: $125\text{ }^\circ\text{C}$ Number of cycles: 10	< 3 %	
Endurance	DIN draft 45 924	P_{\max} : 300 mW Duration: 1000 h	< 5 %	
Solderability	IEC 68-2-58	Solderability: $215\text{ }^\circ\text{C}/4\text{ s}$ $235\text{ }^\circ\text{C}/2\text{ s}$ Resistance to soldering heat: $260\text{ }^\circ\text{C}/10\text{ s}$	< 3 %	95 % of terminations wetted
Robustness of terminations	DIN draft 45 924	Bending of carrier (2 mm bending)	< 3 %	No visible damage

Applications

- Automotive electronics
- Measurement of cooling water and oil temperature

Features

- Thermistor disk with lapped, coplanar front surfaces
- Front surfaces silver-plated
- For clamp contacting

Options

Alternative resistance ratings, rated temperatures and tolerances available on request

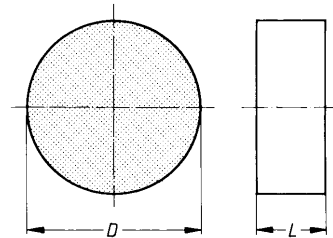

 Termination

TNT0088 - P

$D = 6,5 - 7,2 \text{ mm}$

$L = 0,9 - 1,5 \text{ mm}$

Approx. weight 0,3 g

Climatic category (IEC 68-1)		55/155/21	
Max. power at 25 °C	P_{25}	450	mW
Resistance tolerance	$\Delta R/R_N$	± 5 %	
Rated temperature	T_N	100	°C
B value tolerance	$\Delta B/B$	± 1,5 %	
Dissipation factor (in air)	$\delta_{th}^{1)}$	approx. 5	mW/K
Thermal cooling time constant (in air)	$\tau_c^{1)}$	approx. 7	s
Heat capacity	$C_{th}^{1)}$	approx. 35	mJ/K

Type	R_{100}	R_{25}	No. of R/T characteristic	$B_{25/100}$	Ordering code
	Ω	Ω		K	
K 150/130/A1	12,5	127,9	1306	3450	B57150-K131-A1

1) Depends on mounting situation

Applications

- Automotive electronics
- Measurement of cooling water and oil temperature

Features

- Thermistor disk with lapped, coplanar front surfaces
- Front surfaces silver-plated
- For clamp contacting

Options

Alternative resistance ratings, rated temperatures and tolerances available on request

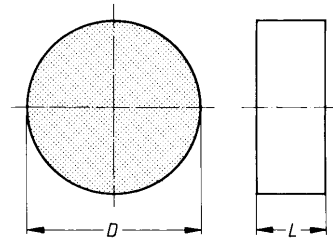

Termination

TNT0088 - P

$D = 2,9 \pm 0,3 \text{ mm}$

$L = 1,3 \pm 0,3 \text{ mm}$

Approx. weight 50 mg

Climatic category (IEC 68-1)		55/250/21	
Max. power at 25 °C	P_{25}	180	mW
Resistance tolerance	$\Delta R/R_N$	$\pm 5 \%$	
Rated temperature	T_N	20	°C
B value tolerance	$\Delta B/B$	$\pm 1,5 \%$	
Dissipation factor (in air)	$\delta_{th}^{1)}$	approx. 1	mW/K
Thermal cooling time constant (in air)	$\tau_c^{1)}$	approx. 5	s
Heat capacity	$C_{th}^{1)}$	approx. 5	mJ/K

Type	R_{20}	R_{25}	No. of R/T characteristic	$B_{25/100}$	Ordering code
	Ω	Ω		K	
K 220/2,1 k/A3	2,5 k	2056,9	1008	3560	B57220-K212-A3

1) Depends on mounting situation

Applications

- Automotive electronics
- Measurement of cooling water and oil temperature

Features

- Thermistor disk with lapped, coplanar front surfaces
- Front surfaces silver-plated
- For clamp-contacting

Options

Alternative resistance ratings, rated temperatures and tolerances available on request

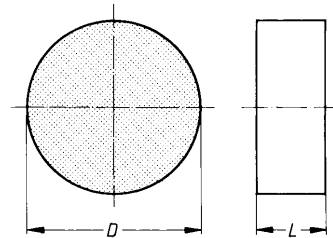

 Termination

TNT0088 - P

R_N (Ω)	D (mm)	L (mm)
39,60	$5,1_{-1,1}$	$2,2_{-1,4}$
77,00	$5,3_{\pm 0,3}$	$1,3_{\pm 0,2}$
144,00	$5,5_{-1,1}$	$2,0_{-1,4}$

Approx. weight 0,1 g

Climatic category (IEC 68-1)		55/155/21	
Max. power at 25 °C	P_{25}	180	mW
Resistance tolerance	$\Delta R/R_N$	$\pm 5\%$	
Rated temperature	T_N	100	°C
B value tolerance	$\Delta B/B$	$\pm 1,5\%$	
Dissipation factor (in air)	$\delta_{th}^{(1)}$	approx. 3	mW/K
Thermal cooling time constant (in air)	$\tau_c^{(1)}$	approx. 30	s
Heat capacity	$C_{th}^{(1)}$	approx. 100	mJ/K

Type	R_{100} Ω	R_{25} Ω	No. of R/T characteristic	$B_{25/100}$ K	Ordering code
M 820/560/A5	39,60	560,2	1009	3930	B57820-M561-A5
M 820/840/A4	77,00	843,2	1006	3550	B57820-M841-A4
M 820/2,1 k/A1	144,00	2052,6	2002	3940	B57820-M212-A1

1) Depends on mounting situation

Applications

- For high temperatures and short response times

Features

- Fast response
- Thermistor bead hermetically sealed in glass body
- Glass body provides protection from hostile environments and makes the NTC suitable for use in many different media
- Silver-plated Fe/Ni leads

Options

Paired characteristic available

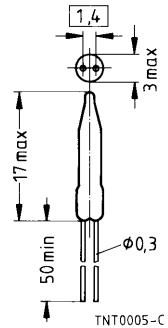

Dimensions in mm
Approx. weight 0,3 g

Climatic category (IEC 68-1)		55/250/56	
Max. power at 25 °C	P_{25}	140	mW
Resistance tolerance	$\Delta R/R_N$	$\pm 5\%, \pm 10\%, \pm 20\%$	
Rated temperature	T_N	20	°C
B value tolerance	$\Delta B/B$	$\pm 3\%$	
Dissipation factor (in air)	δ_{th}	approx. 0,8	mW/K
Thermal cooling time constant (in air)	τ_c	approx. 3	s
Heat capacity	C_{th}	approx. 2,4	mJ/K
Insulation resistance ($V = 100$ Vdc)	R_{is}	> 100	MΩ

Type	R_{20} Ω	R_{25} Ω	No. of R/T characteristic	$B_{25/100}$ K	Ordering code
K 17/2,1 k/+	2,5 k	2,067 k	1018	3430	B57017-K212+
K 17/3,3 k/+	4 k	3,307 k	1101	3430	B57017-K332+
K 17/8,2 k/+	10 k	8,268 k	1101	3430	B57017-K822+
K 17/80,0 k/+	100 k	80,380 k	4005	3950	B57017-K803+

- +: J for $\Delta R/R_N = \pm 5\%$
 K for $\Delta R/R_N = \pm 10\%$
 M for $\Delta R/R_N = \pm 20\%$

Applications

- For small measuring points
- Measurement of gas flow rates
- Measurement in vacuum

Features

- Extremely fast response
- For high temperatures
- Smallest size available
- Glass-coated thermistor bead
- Platinum leads

Options

Also available with radial leads and paired characteristic

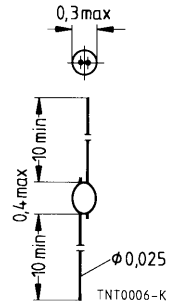

Dimensions in mm
Approx. weight 0,3 g

Climatic category (IEC 68-1)		55/200/56	
Max. power at 25 °C	P_{25}	18	mW
Resistance tolerance	$\Delta R/R_N$	$\pm 5\%, \pm 10\%, \pm 20\%$	
Rated temperature	T_N	20	°C
B value tolerance	$\Delta B/B$	$\pm 3\%$	
Dissipation factor (in air)	δ_{th}	approx. 0,14	mW/K
Thermal cooling time constant (in air)	τ_c	approx. 0,4	s
Heat capacity	C_{th}	approx. 56	$\mu\text{J/K}$

Type	R_{20} Ω	R_{25} Ω	No. of R/T characteristic	$B_{25/100}$ K	Ordering code
K 19/9,9 k/+	12 k	9,921 k	1101	3430	B57019-K992-+

- + : J for $\Delta R/R_N = \pm 5\%$
 K for $\Delta R/R_N = \pm 10\%$
 M for $\Delta R/R_N = \pm 20\%$

Not for new design (replaced by M185)

Applications

- For high temperatures and short response times

Features

- Fast response
- Thermistor bead hermetically sealed in glass body
- Glass body provides protection from hostile environments and makes the NTC suitable for use in many different media
- Silver-plated Fe/Ni leads

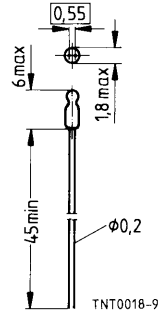

Dimensions in mm
Approx. weight 40 mg

Climatic category (IEC 68-1)		55/200/56	
Max. power at 25 °C	P_{25}	95	mW
Resistance tolerance	$\Delta R/R_N$	$\pm 5\%, \pm 10\%, \pm 20\%$	
Rated temperature	T_N	25	°C
B value tolerance	$\Delta B/B$	$\pm 3\%$	
Dissipation factor (in air)	δ_{th}	approx. 0,7	mW/K
Thermal cooling time constant (in air)	τ_c	approx. 14	s
Heat capacity	C_{th}	approx. 10	mJ/K
Insulation resistance ($V = 100$ Vdc)	R_{is}	> 100	M Ω

Type	R_{25} Ω	No. of R/T characteristic	$B_{25/100}$ K	Ordering code
M 85/4,7 k/+	4,7 k	1101	3430	B57085-M472-+
M 85/10,0 k/+	10,0 k	1101	3430	B57085-M103-+
M 85/47,0 k/+	47,0 k	4005	3950	B57085-M473-+
M 85/100,0 k/+	100,0 k	4005	3950	B57085-M104-+

- +: J for $\Delta R/R_N = \pm 5\%$
 K for $\Delta R/R_N = \pm 10\%$
 M for $\Delta R/R_N = \pm 20\%$

Applications

- For high temperatures and short response times

Features

- Thermistor bead hermetically sealed in glass body
- Glass body provides protection from hostile environments and makes the NTC suitable for use in many different media
- Silver-plated Fe/Ni leads

Options

Alternative resistance ratings and tolerances available on request

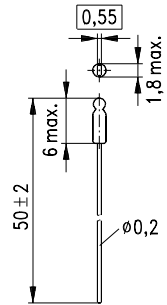

TNT0018-9

Dimensions in mm
 Approx. weight 40 mg

Climatic category (IEC 68-1)		55/200/56	
Max. power at 25 °C	P_{25}	95	mW
Resistance tolerance	$\Delta R/R_N$	$\pm 3 \%, \pm 5 \%$	
Rated temperature	T_N	25	°C
B value tolerance	$\Delta B/B$	$\pm 1,5 \%$	
Dissipation factor (in air)	δ_{th}	approx. 0,9	mW/K
Thermal cooling time constant (in air)	τ_c	approx. 13	s
Heat capacity	C_{th}	approx. 12	mJ/K
Insulation resistance ($V = 100$ Vdc)	R_{is}	> 100	MΩ

Type	R_{25} Ω	No. of R/T characteristic	$B_{25/100}$ K	Ordering code
M 185/ 47 k	47 k	2910	3950	B57185-M473+
M 185/100 k	100 k	2910	3950	B57185-M104+

+: J for $\Delta R/R_N = \pm 5 \%$
 H for $\Delta R/R_N = \pm 3 \%$

Applications

- Automotive electronics
- Industrial electronics

Features

- For high temperatures
- Cost-effective
- Thermistor bead hermetically sealed in glass body
- Axial lead version
- Tinned FeNi leads
- Only available on tape (PU: 1000 pcs); see chapter on taping, [page 160](#)

Options

Alternative resistance ratings and tolerances available on request

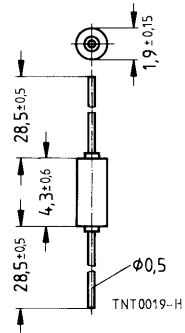

Dimensions in mm
Approx. weight 0,2 g

Climatic category (IEC 68-1)		55/300/56	
Max. power at 25 °C	P_{25}	400	mW
Resistance tolerance	$\Delta R/R_N$	± 10 %	
Rated temperature	T_N	25	°C
B value tolerance	$\Delta B/B$	see table below	
Dissipation factor (in air)	δ_{th}	approx. 2,5	mW/K
Thermal cooling time constant (in air)	τ_c	approx. 4	s
Heat capacity	C_{th}	approx. 10	mJ/K

Type	R_{25} Ω	No. of R/T characteristic	$B_{25/100}$ K	$\Delta B/B$ %	Ordering code
M 87/2 k/K100	2 k	8010	3474	2,5	B57087-M202-K100
M 87/3 k/K100	3 k	8010	3474	2,5	B57087-M302-K100
M 87/5 k/K100	5 k	8010	3474	2,5	B57087-M502-K100
M 87/10 k/K100	10 k	8010	3474	2,5	B57087-M103-K100
M 87/20 k/K100	20 k	8016	3988	1,5	B57087-M203-K100
M 87/50 k/K100	50 k	8016	3988	1,5	B57087-M503-K100
M 87/100 k/K100	100 k	8016	3988	1,5	B57087-M104-K100

Applications

- Temperature compensation

Features

- Lacquer-coated thermistor disk
- Tinned copper leads
- Low resistance values
- Marked with resistance and tolerance
- Available on tape (PU: 1500 pcs)

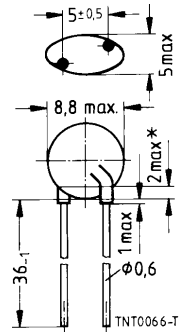

*May be free of lacquer

Dimensions in mm
Approx. weight 0,6 g

Climatic category (IEC 68-1)		55/125/21	
Max. power at 25 °C	P_{25}	500	mW
Resistance tolerance	$\Delta R/R_N$	$\pm 5\%, \pm 10\%$	
Rated temperature	T_N	25	°C
B value tolerance	$\Delta B/B$	$\pm 3\%$	
Dissipation factor (in air)	δ_{th}	approx. 8	mW/K
Thermal cooling time constant (in air)	τ_c	approx. 30	s
Heat capacity	C_{th}	approx. 240	mJ/K

Type	R_{25} Ω	No. of R/T characteristic	$B_{25/100}$ K	Ordering code
K 153/4,7/+	4,7	1202	2800	B57153-K479-+
K 153/10/+	10,0	1202	2800	B57153-K100-+

- +: J for $\Delta R/R_N = \pm 5\%$
K for $\Delta R/R_N = \pm 10\%$

For reliability data refer to K 164, [page 59](#).

Applications

- Temperature compensation
- Temperature measurement
- Temperature control

Features

- Wide resistance range
- Cost-effective
- Lacquer-coated thermistor disk
- Tinned copper leads
- Marked with resistance and tolerance
- Available on tape (PU: 1500 pcs)

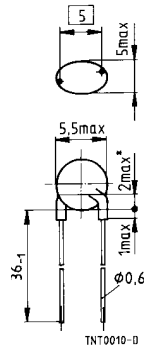

*May be free of lacquer

Dimensions in mm
Approx. weight 0,4 g

Climatic category (IEC 68-1)		55/125/21	
Max. power at 25 °C	P_{25}	450	mW
Resistance tolerance	$\Delta R/R_N$	$\pm 5\%, \pm 10\%$	
Rated temperature	T_N	25	°C
B value tolerance	$\Delta B/B$	$\pm 3\%$	
Dissipation factor (in air)	δ_{th}	approx. 7,5	mW/K
Thermal cooling time constant (in air)	τ_c	approx. 20	s
Heat capacity	C_{th}	approx. 150	mJ/K

Type	R_{25} Ω	No. of R/T characteristic	$B_{25/100}$ K	Ordering code
K 164/15/+	15	1203	2900	B57164-K150+
K 164/22/+	22	1203	2900	B57164-K220+
K 164/33/+	33	1203	2900	B57164-K330+
K 164/47/+	47	1302	3000	B57164-K470+
K 164/68/+	68	1303	3050	B57164-K680+
K 164/100/+	100	1305	3200	B57164-K101+
K 164/150/+	150	1305	3200	B57164-K151+
K 164/220/+	220	1305	3200	B57164-K221+
K 164/330/+	330	1306	3450	B57164-K331+
K 164/470/+	470	1306	3450	B57164-K471+
K 164/680/+	680	1307	3560	B57164-K681+

Type	R_{25} Ω	No. of R/T characteristic	$B_{25/100}$ K	Ordering code
K 164/1 k/+	1 k	1011	3730	B57164-K102+
K 164/1,5 k/+	1,5 k	1013	3900	B57164-K152+
K 164/2,2 k/+	2,2 k	1013	3900	B57164-K222+
K 164/3,3 k/+	3,3 k	4001	3950	B57164-K332+
K 164/4,7 k/+	4,7 k	4001	3950	B57164-K472+
K 164/6,8 k/+	6,8 k	2903	4200	B57164-K682+
K 164/10 k/+	10 k	2904	4300	B57164-K103+
K 164/15 k/+	15 k	1014	4250	B57164-K153+
K 164/22 k/+	22 k	1012	4300	B57164-K223+
K 164/33 k/+	33 k	1012	4300	B57164-K333+
K 164/47 k/+	47 k	4003	4450	B57164-K473+
K 164/68 k/+	68 k	2005	4600	B57164-K683+
K 164/100 k/+	100 k	2005	4600	B57164-K104+
K 164/150 k/+	150 k	2005	4600	B57164-K154+
K 164/220 k/+	220 k	2007	4830	B57164-K224+
K 164/330 k/+	330 k	2006	5000	B57164-K334+
K 164/470 k/+	470 k	2006	5000	B57164-K474+

+ : J for $\Delta R/R_N = \pm 5\%$
K for $\Delta R/R_N = \pm 10\%$

Reliability data

Test	Standard	Test conditions	$\Delta R_{25}/R_{25}$ (typ.)	Remarks
Storage in dry heat	IEC 68-2-2	Storage at upper category temperature T : 125 °C t : 1000 h	< 3 %	No visible damage
Storage in damp heat, steady state	IEC 68-2-3	Temperature of air: 40 °C Relative humidity of air: 93 % Duration: 21 days	< 3 %	No visible damage
Rapid temperature cycling	IEC 68-2-14	Lower test temperature: - 55 °C Upper test temperature: 125 °C Number of cycles: 5	< 3 %	No visible damage
Endurance		P_{max} : 450 mW Duration: 1000 h	< 3 %	No visible damage
Long-term stability (empirical value)		Temperature: 125 °C Duration: 10 000 h	< 5 %	No visible damage

Applications

- Temperature compensation
- Temperature measurement

Features

- Uncoated thermistor disk
- Leads: copper-clad Fe wires, tinned

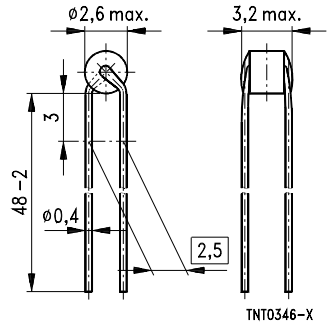

Dimensions in mm
Approx. weight 0,2 g

Climatic category (IEC 68-1)		55/155/21	
Max. power at 25 °C	P_{25}	200	mW
Resistance tolerance	$\Delta R/R_N$	$\pm 5 \%, \pm 10 \%$	
Rated temperature	T_N	25	°C
B value tolerance	$\Delta B/B$	$\pm 1,5 \%$	
Dissipation factor (in air)	δ_{th}	approx. 3,5	mW/K
Thermal cooling time constant (in air)	τ_c	approx. 12	s
Heat capacity	C_{th}	approx. 42	mJ/K

Type	R_{25} Ω	No. of R/T characteristic	$B_{25/100}$ K	Ordering code
M 1891/1 k/+	1 k	1010	3530	B57891-M1102-+
M 1891/10 k/+	10 k	4901	3950	B57891-M1103-+
M 1891/47 k/+	47 k	2904	4300	B57891-M1473-+
M 1891/100 k/+	100 k	4003	4450	B57891-M1104-+

+ : J for $\Delta R/R_N = \pm 5 \%$
 K for $\Delta R/R_N = \pm 10 \%$

Applications

- Temperature compensation
- Temperature measurement
- Temperature control

Features

- Wide resistance range
- Cost-effective
- Lacquer-coated thermistor disk
- Leads: copper-clad Fe wire, tinned
- Marked with resistance and tolerance
- Available on tape (PU: 1500 pcs)

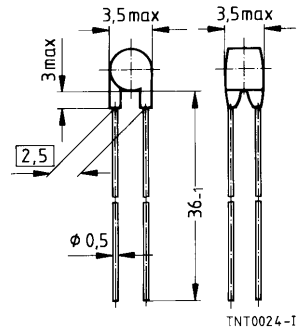

Dimensions in mm
Approx. weight 0,2 g

Climatic category (IEC 68-1)		55/125/21	
Max. power at 25 °C	P_{25}	200	mW
Resistance tolerance	$\Delta R/R_N$	$\pm 5\%, \pm 10\%$	
Rated temperature	T_N	25	°C
B value tolerance	$\Delta B/B$	$\pm 3\%$	
Dissipation factor (in air)	δ_{th}	approx. 3,5	mW/K
Thermal cooling time constant (in air)	τ_c	approx. 12	s
Heat capacity	C_{th}	approx. 40	mJ/K

Type	R_{25} Ω	No. of R/T characteristic	$B_{25/100}$ K	Ordering code
M 891/1 k/+	1 k	1009	3930	B57891-M102+
M 891/1,5 k/+	1,5 k	1008	3560	B57891-M152+
M 891/2,2 k/+	2,2 k	1013	3900	B57891-M222+
M 891/3,3 k/+	3,3 k	2003	3980	B57891-M332+
M 891/4,7 k/+	4,7 k	2003	3980	B57891-M472+
M 891/6,8 k/+	6,8 k	2003	3980	B57891-M682+
M 891/10 k/+	10 k	4901	3950	B57891-M103+
M 891/15 k/+	15 k	2004	4100	B57891-M153+
M 891/22 k/+	22 k	2904	4300	B57891-M223+
M 891/33 k/+	33 k	2904	4300	B57891-M333+
M 891/47 k/+	47 k	4002	4250	B57891-M473+
M 891/68 k/+	68 k	4002	4250	B57891-M683+

B57891
M 891

Type	R_{25} Ω	No. of R/T characteristic	$B_{25/100}$ K	Ordering code
M 891/100 k/+	100 k	4003	4450	B57891-M104-+
M 891/150 k/+	150 k	2005	4600	B57891-M154-+
M 891/220 k/+	220 k	2005	4600	B57891-M224-+
M 891/330 k/+	330 k	2007	4830	B57891-M334-+
M 891/470 k/+	470 k	2006	5000	B57891-M474-+

+ : J for $\Delta R/R_N = \pm 5\%$
K for $\Delta R/R_N = \pm 10\%$

Reliability data

Test	Standard	Test conditions	$\Delta R_{25}/R_{25}$ (typical)	Remarks
Storage in dry heat	IEC 68-2-2	Storage at upper category temperature T : 125 °C t : 1000 h	< 3 %	No visible damage
Storage in damp heat, steady state	IEC 68-2-3	Temperature of air: 40 °C Relative humidity of air: 93 % Duration: 21 days	< 2 %	No visible damage
Rapid temperature cycling	IEC 68-2-14	Lower test temperature: -55 °C Upper test temperature: 125 °C Number of cycles: 5	< 2 %	No visible damage
Endurance		P_{max} : 200 mW Duration: 1000 h	< 3 %	No visible damage
Long-term stability (empirical value)		Temperature: 125 °C Duration: 10 000 h	< 5 %	No visible damage

Applications

- Heating and air conditioning systems
- Automotive electronics

Features

- High accuracy between 0 °C and 70 °C
- Favorable price/performance ratio
- Curve-tracking multipoint sensor
- Rugged design, epoxy resin encapsulation
- Leads: copper-clad Fe wire, tinned
- Available on tape (PU: 1500 pcs)

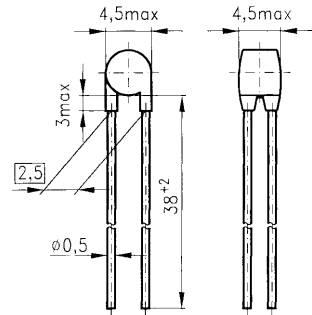

TNT0191-F

Dimensions in mm
Approx. weight 0,2 g

Climatic category (IEC 68-1)		55/155/56	
Max. power at 25 °C	P_{25}	200	mW
Temperature tolerance (0 ... 70 °C)	ΔT	$\pm 0,5, \pm 1, \pm 2$	K
Rated temperature	T_N	25	°C
Dissipation factor (in air)	δ_{th}	approx. 4,0	mW/K
Thermal cooling time constant (in air)	τ_c	approx. 15	s
Heat capacity	C_{th}	approx. 60	mJ/K

Type	R_{25} Ω	No. of R/T characteristic	$B_{25/100}$ K	Ordering code
S 891/2,2 k/+9	2,2 k	1008	3560	B57891-S222-+9
S 891/10 k/+9	10 k	4901	3950	B57891-S103-+9
S 891/20 k/+9	20 k	2904	4300	B57891-S203-+9
S 891/100 k/+9	100 k	4003	4450	B57891-S104-+9

- + : G for $\Delta T = \pm 0,5$ K
 H for $\Delta T = \pm 1$ K
 J for $\Delta T = \pm 2$ K

B57891
S 891

R/T characteristics

Number	1008	4901	2904	4003
T (°C)	$R_{25} = 2,2 \text{ k}\Omega$	$R_{25} = 10 \text{ k}\Omega$	$R_{25} = 20 \text{ k}\Omega$	$R_{25} = 100 \text{ k}\Omega$
	R_T (Ω)	R_T (Ω)	R_T (Ω)	R_T (Ω)
-55,0	116830	878900	2429200	10381000
-50,0	86499	617590	1688800	7370700
-45,0	64515	439340	1184900	5272300
-40,0	48466	316180	838770	3798800
-35,0	36666	230060	598950	2756500
-30,0	27931	169150	431350	2014200
-25,0	21395	125550	312810	1480100
-20,0	16538	94143	229310	1097600
-15,0	12838	71172	169020	817440
-10,0	10051	54308	125850	614070
- 5,0	7931,0	41505	94153	463310
0,0	6306,3	32014	71126	352430
1,0	6026,1	30452	67324	333930
2,0	5760,2	28976	63749	316490
3,0	5507,6	27580	60385	300050
4,0	5267,6	26260	57218	284560
5,0	5039,6	25011	54237	269950
6,0	4822,8	23828	51429	256160
7,0	4616,6	22708	48783	243150
8,0	4420,5	21648	46289	230870
9,0	4233,9	20643	43938	219270
10,0	4056,3	19691	41719	208310
11,0	3886,0	18788	39640	197960
12,0	3723,9	17932	37676	188170
13,0	3569,6	17120	35820	178920
14,0	3422,5	16350	34067	170170
15,0	3282,5	15618	32409	161890
16,0	3148,9	14923	30841	154060
17,0	3021,7	14236	29358	146640
18,0	2900,3	13636	27954	139620
19,0	2784,5	13040	26625	132970
20,0	2674,0	12474	25367	126660
21,0	2570,5	11928	24176	120760
22,0	2471,6	11409	23047	115160
23,0	2377,0	10915	21977	109840
24,0	2286,5	10446	20962	104790
25,0	2200,0	10000	20000	100000

R/T characteristics

Number	1008	4901	2904	4003
T (°C)	$R_{25} = 2,2 \text{ k}\Omega$	$R_{25} = 10 \text{ k}\Omega$	$R_{25} = 20 \text{ k}\Omega$	$R_{25} = 100 \text{ k}\Omega$
	R_T (Ω)	R_T (Ω)	R_T (Ω)	R_T (Ω)
26,0	2118,6	9577,7	19089	95178
27,0	2040,6	9175,6	18225	90617
28,0	1965,8	8792,6	17404	86302
29,0	1894,2	8427,7	16624	82218
30,0	1825,5	8080,0	15884	78351
31,0	1756,6	7748,5	15169	74822
32,0	1690,8	7432,4	14491	71469
33,0	1627,9	7131,0	13847	68282
34,0	1567,6	6843,4	13235	65253
35,0	1510,0	6569,0	12654	62372
36,0	1454,8	6307,0	12101	59632
37,0	1401,9	6057,0	11575	57026
38,0	1351,3	5818,1	11076	54546
39,0	1302,7	5590,0	10600	52185
40,0	1256,3	5372,0	10148	49937
41,0	1213,0	5165,1	9721,1	47801
42,0	1171,5	4967,3	9314,5	45767
43,0	1131,6	4778,0	8926,9	43828
44,0	1093,2	4596,9	8557,5	41980
45,0	1056,3	4423,5	8205,3	40218
46,0	1020,9	4257,6	7869,3	38538
47,0	986,76	4098,7	7548,9	36936
48,0	953,94	3946,5	7243,1	35408
49,0	922,37	3800,7	6951,2	33949
50,0	891,98	3661,0	6672,6	32557
51,0	861,61	3525,8	6404,6	31207
52,0	832,45	3396,2	6148,9	29919
53,0	804,46	3272,2	5904,6	28691
54,0	777,57	3153,2	5671,4	27520
55,0	751,75	3039,3	5448,6	26402
56,0	726,93	2930,0	5235,7	25335
57,0	703,09	2825,2	5032,3	24317
58,0	680,17	2724,8	4837,8	23344
59,0	658,13	2628,4	4651,8	22415
60,0	636,93	2535,9	4473,9	21527
61,0	616,88	2447,6	4303,6	20691
62,0	597,56	2362,9	4140,5	19890
63,0	578,95	2281,5	3984,4	19125
64,0	576,10	2203,4	3835,0	18393
65,0	543,71	2128,3	3691,8	17693

B57891
S 891

R/T characteristics

Number	1008	4901	2904	4003
<i>T</i> (°C)	$R_{25} = 2,2 \text{ k}\Omega$	$R_{25} = 10 \text{ k}\Omega$	$R_{25} = 20 \text{ k}\Omega$	$R_{25} = 100 \text{ k}\Omega$
	$R_T (\Omega)$	$R_T (\Omega)$	$R_T (\Omega)$	$R_T (\Omega)$
66,0	527,03	2056,1	3554,7	17023
67,0	510,95	1986,7	3423,3	16381
68,0	495,43	1920,0	3297,4	15767
69,0	480,47	1855,9	3176,6	15179
70,0	466,03	1794,2	3060,9	14616
75,0	400,27	1518,3	2551,0	12097
80,0	344,97	1290,1	2135,5	10053
85,0	299,02	1100,2	1798,6	8376,1
90,0	260,09	941,79	1521,4	7003,9
95,0	227,47	808,96	1290,5	5893,7
100,0	199,63	697,22	1098,8	4977,7
105,0	175,21	603,97	940,06	4214,6
110,0	154,22	524,93	807,17	3580,3
115,0	136,16	457,33	694,85	3050,4
120,0	120,53	399,63	600,13	2606,7
125,0	107,15	350,59	520,13	2233,2
130,0	95,513	308,44	452,17	1918,6
135,0	85,188	271,92	394,41	1651,5
140,0	76,154	240,34	345,01	1425,3
145,0	68,306	212,85	302,77	1236,7
150,0	61,402	188,95	266,42	1075,8
155,0	55,425	168,13	235,08	939,33

Resistance and temperature tolerances versus temperature ($\Delta T = 0,5$ K)

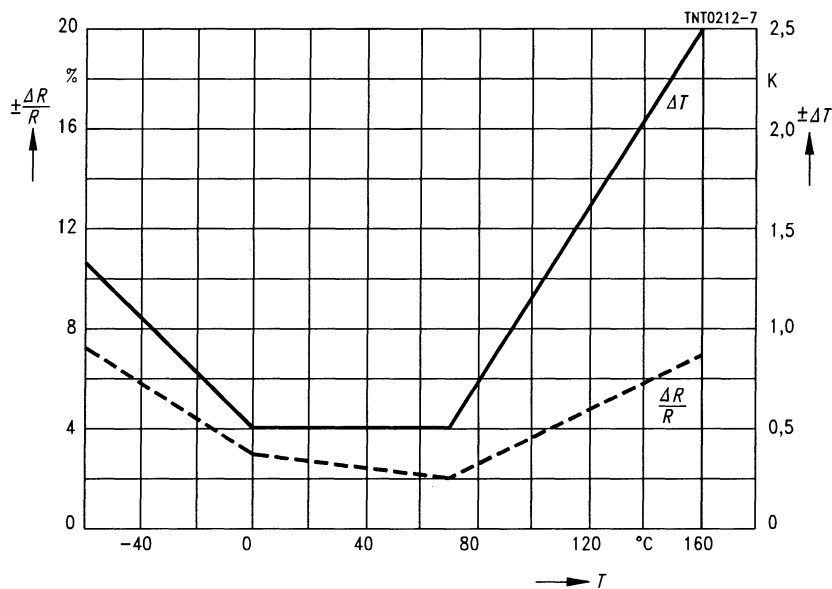

Resistance and temperature tolerances versus temperature ($\Delta T = 1$ K)

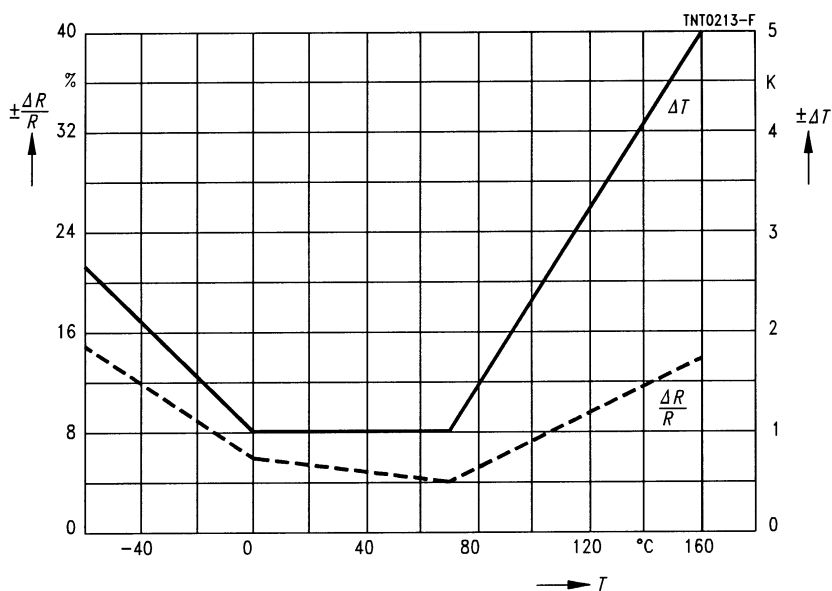

Resistance and temperature tolerances versus temperature ($\Delta T = 2 \text{ K}$)

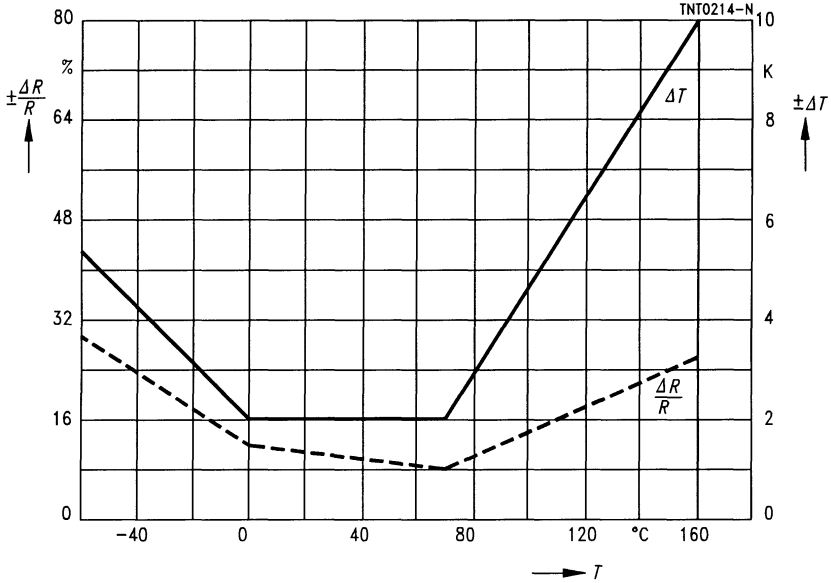

Reliability data

Test	Standard	Test conditions	$\Delta R_{25}/R_{25}$ (typical)	Remarks
Storage in dry heat	IEC 68-2-2	Storage at upper category temperature T: 155 °C t: 1000 h	< 3 %	No visible damage
Storage in damp heat, steady state	IEC 68-2-3	Temperature of air: 40 °C Relative humidity of air: 93 % Duration: 56 days	< 1 %	No visible damage
Rapid temperature cycling	IEC 68-2-14	Lower test temperature: -55 °C Upper test temperature: 155 °C Number of cycles: 5	< 1 %	No visible damage
Long-term stability (empirical value)		Temperature: 70 °C Duration: 10 000 h	< 3 %	No visible damage

Applications

- Heating and air conditioning systems
- Industrial electronics
- Automotive electronics

Features

- Fast response
- High measuring accuracy
- Different tolerances available
- Epoxy resin encapsulation
- PTFE-insulated leads of nickel wire, AWG 30

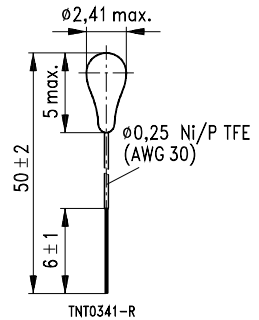

Dimensions in mm
Approx. weight 60 mg

Options

Non-standard lead lengths

Climatic category (IEC 68-1)		55/155/56	
Max. power at 25 °C	P_{25}	60	mW
Resistance tolerance	$\Delta R/R_N$	$\pm 1\%, \pm 3\%, \pm 5\%$	
Rated temperature	T_N	25	°C
Dissipation factor (in air)	δ_{th}	approx. 1.5	mW/K
Thermal cooling time constant (in air)	τ_c	approx. 15	s
Heat capacity	C_{th}	approx. 22,5	mJ/K

Type	R_{25} Ω	No. of R/T characteristic	$B_{25/100}$ K	$\Delta B/B$ %	Ordering code
S 861/3 k/+ 40	3 k	8016	3988	$\pm 1,0$	B57861-S302+40
S 861/5 k/+ 40	5 k	8016	3988	$\pm 1,0$	B57861-S502+40
S 861/10 k/+ 40	10 k	8016	3988	$\pm 1,0$	B57861-S103+40
S 861/30 k/+ 40	30 k	8018	3964	$\pm 1,0$	B57861-S303+40

- +: F for $\Delta R/R_N = \pm 1\%$
 H for $\Delta R/R_N = \pm 3\%$
 J for $\Delta R/R_N = \pm 5\%$

B57861
S 861

Reliability data

Test	Standard	Test conditions	$\Delta R_{25}/R_{25}$ (typical)	Remarks
Storage in dry heat	IEC 68-2-2	Storage at upper category temperature T : 155 °C t : 1000 h	< 1 %	No visible damage
Storage in damp heat, steady state	IEC 68-2-3	Temperature of air: 40 °C Relative humidity of air: 93 % Duration: 56 days	< 1 %	No visible damage
Rapid temperature cycling	IEC 68-2-14	Lower test temperature: -55 °C Upper test temperature: 155 °C Number of cycles: 5	< 0,5 %	No visible damage
Long-term stability (empirical value)		Temperature: + 70 °C Duration: 10 000 h	< 2 %	No visible damage

Applications

- High-precision measuring
- Medical engineering

Features

- Fast response
- High measuring accuracy
- Excellent long-term stability
- Epoxy resin encapsulation
- PTFE-insulated leads of nickel wire, AWG 30

Options

Non-standard lead lengths

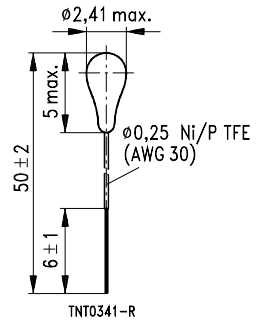

Dimensions in mm
Approx. weight 60 mg

Climatic category (IEC 68-1)		40/100/56	
Max. power at 25 °C	P_{25}	60	mW
Temperature tolerance (30 ... 50 °C)	ΔT	± 0,1	K
Rated temperature	T_N	25	°C
Dissipation factor (in air)	δ_{th}	approx. 1,5	mW/K
Thermal cooling time constant (in air)	τ_c	approx. 15	s
Heat capacity	C_{th}	approx. 22,5	mJ/K

Type	R_{25}	No. of R/T characteristic	$B_{25/100}$	Ordering code
	Ω		K	
S 861/5 k/C1	5 k	8016	3988	B57861-S502-C1

B57861
S 861

R/T characteristic

Number		8016 ($R_{25} = 5 \text{ k}\Omega$)			
T (°C)	R_T	T (°C)	R_T	T (°C)	R_T
-40,0	168250	21,0	5970,1	51,0	1734,4
-35,0	121290	22,0	5708,9	52,0	1670,1
-30,0	88500	23,0	5460,6	53,0	1608,5
-25,0	65185	24,0	5224,5	54,0	1549,6
-20,0	48535	25,0	5000,0	55,0	1493,1
-15,0	36465	26,0	4786,0	56,0	1439,0
-10,0	27665	27,0	4582,5	57,0	1387,1
- 5,0	21158	28,0	4388,7	58,0	1337,4
0,0	16325	29,0	4204,2	59,0	1289,7
1,0	15514	30,0	4028,5	60,0	1244,0
2,0	14747	31,0	3860,9	61,0	1200,1
3,0	14024	32,0	3701,2	62,0	1158,0
4,0	13340	33,0	3549,1	63,0	1117,6
5,0	12694	34,0	3404,0	64,0	1078,8
6,0	12083	35,0	3265,7	65,0	1041,5
7,0	11505	36,0	3133,7	66,0	1005,7
8,0	10958	37,0	3007,8	67,0	971,33
9,0	10440	38,0	2887,7	68,0	938,29
10,0	9950,0	39,0	2773,0	69,0	906,53
11,0	9484,5	40,0	2663,5	70,0	876,00
12,0	9043,5	41,0	2558,7	75,0	740,69
13,0	8625,6	42,0	2458,7	80,0	629,00
14,0	8229,5	43,0	2363,1	85,0	536,17
15,0	7853,9	44,0	2271,7	90,0	458,85
16,0	7497,6	45,0	2184,4	95,0	394,26
17,0	7159,6	46,0	2100,8	100,0	340,00
18,0	6838,8	47,0	2021,0		
19,0	6534,2	48,0	1944,6		
20,0	6245,0	49,0	1871,5		
		50,0	1801,5		

Resistance and temperature tolerances versus temperature

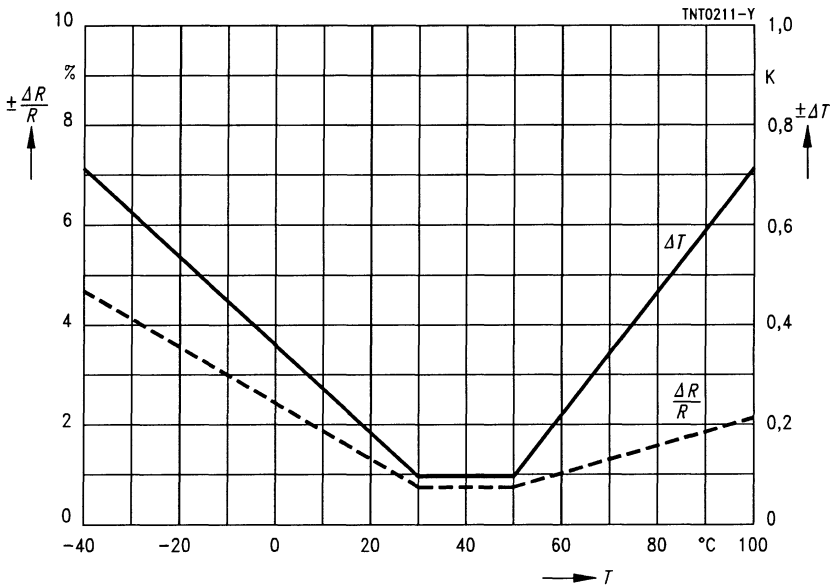

Reliability data

Test	Standard	Test conditions	$\Delta R_{25}/R_{25}$ (typical)	Remarks
Storage in dry heat	IEC 68-2-2	Storage at upper category temperature T: 100 °C t: 1000 h	< 0,5 %	No visible damage
Storage in damp heat, steady state	IEC 68-2-3	Temperature of air: 40 °C Relative humidity of air: 93 % Duration: 56 days	< 1 %	No visible damage
Rapid temperature cycling	IEC 68-2-14	Lower test temperature: - 40 °C Upper test temperature: 100 °C Number of cycles: 5	< 0,5 %	No visible damage
Long-term stability (empirical value)		Temperature: + 50 °C Duration: 10 000 h	< 1,5 %	No visible damage

Applications

- Heating and air conditioning systems
- Industrial electronics
- Automotive electronics

Features

- Fast response
- High measuring accuracy
- Different tolerances available
- Epoxy resin encapsulation
- Silver-plated MONEL leads

Options

Non-standard lead lengths

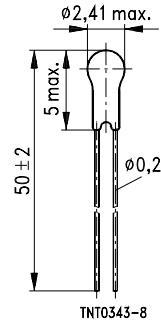

Dimensions in mm
Approx. weight 60 mg

Climatic category (IEC 68-1)		55/155/56	
Max. power at 25 °C	P_{25}	60	mW
Temperature tolerance	$\Delta R/R_N$	$\pm 1\%, \pm 3\%, \pm 5\%$	
Rated temperature	T_N	25	°C
Dissipation factor (in air)	δ_{th}	approx. 1	mW/K
Thermal cooling time constant (in air)	τ_c	approx. 15	s
Heat capacity	C_{th}	approx. 15	mJ/K

Type	R_{25} Ω	No. of R/T characteristic	$B_{25/100}$ K	$\Delta B/B$ %	Ordering code
S 867/3 k/+ 40	3 k	8016	3988	$\pm 1,0$	B57867-S302+40
S 867/5 k/+ 40	5 k	8016	3988	$\pm 1,0$	B57867-S502+40
S 867/10 k/+ 40	10 k	8016	3988	$\pm 1,0$	B57867-S103+40
S 867/30 k/+ 40	30 k	8018	3964	$\pm 1,0$	B57867-S303+40

- +: F for $\Delta R/R_N = \pm 1\%$
 H for $\Delta R/R_N = \pm 3\%$
 J for $\Delta R/R_N = \pm 5\%$

For reliability data refer to S 861, page 70.

Applications

- Heating and air conditioning systems
- Industrial electronics
- Automotive electronics

Features

- Fast response
- Accuracy of 0,2 K between 0 °C and 70 °C
- Excellent long-term stability
- Uni curve sensor
- Epoxy resin encapsulation
- PTFE-insulated leads of nickel wire, AWG 30

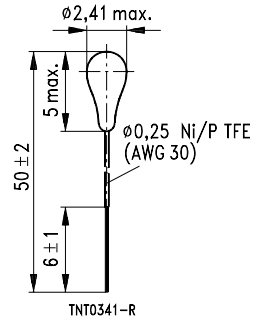

Dimensions in mm
 Approx. weight 60 mg

Climatic category (IEC 68-1)		55/155/56	
Max. power at 25 °C	P_{25}	60	mW
Temperature tolerance (0 ... 70 °C)	ΔT	$\pm 0,2, \pm 0,5$	K
Rated temperature	T_N	25	°C
Dissipation factor (in air)	δ_{th}	approx. 1,5	mW/K
Thermal cooling time constant (in air)	τ_c	approx. 15	s
Heat capacity	C_{th}	approx. 22,5	mJ/K

Type	R_{25} Ω	No. of R/T characteristic	$B_{25/100}$ K	Ordering code
S 863/3 k/+ 40	3 k	8016	3988	B57863-S302-+40
S 863/5 k/+ 40	5 k	8016	3988	B57863-S502-+40
S 863/10 k/+ 40	10 k	8016	3988	B57863-S103-+40
S 863/30 k/+ 40	30 k	8018	3964	B57863-S303-+40

+: F for $\Delta T = 0,2$ K
 G for $\Delta T = 0,5$ K

R/T characteristics

Number	8016	8016	8016	8018
T (°C)	$R_{25} = 3 \text{ k}\Omega$	$R_{25} = 5 \text{ k}\Omega$	$R_{25} = 10 \text{ k}\Omega$	$R_{25} = 30 \text{ k}\Omega$
	R_T (Ω)	R_T (Ω)	R_T (Ω)	R_T (Ω)
-55,0	288910	481520	963000	–
-50,0	201030	335050	670100	–
-45,0	141510	235840	471700	–
-40,0	100950	168250	336500	907200
-35,0	72777	121290	242600	663000
-30,0	53100	88500	177000	489600
-25,0	39111	65185	130400	365100
-20,0	29121	48535	97070	274590
-15,0	21879	36465	72930	208350
-10,0	16599	27665	55330	159390
- 5,0	12695	21158	42320	122910
0,0	9795,0	16325	32650	954490
1,0	9308,1	15514	31030	90870
2,0	8848,5	14747	29490	86490
3,0	8414,3	14024	28050	82350
4,0	8004,0	13340	26680	78420
5,0	7616,3	12694	25390	74730
6,0	7249,6	12083	24170	71220
7,0	6902,8	11505	23010	67890
8,0	6574,7	10958	21920	64710
9,0	6264,1	10440	20880	61740
10,0	5970,0	9950,0	19900	58890
11,0	5690,7	9484,5	18970	56190
12,0	5426,1	9043,5	18090	53640
13,0	5175,4	8625,6	17250	51210
14,0	4937,7	8229,5	16460	48900
15,0	4712,3	7853,9	15710	46710
16,0	4498,6	7497,6	15000	44640
17,0	4295,8	7159,6	14320	42660
18,0	4103,3	6383,8	13680	40800
19,0	3920,6	6534,2	13070	39030
20,0	3747,0	6245,0	12490	37320
21,0	3582,1	5970,1	11940	35700
22,0	3425,3	5708,9	11420	34170
23,0	3276,4	5460,6	10920	32730
24,0	3134,7	5224,5	10450	31320
25,0	3000,0	5000,0	10000	30000

R/T characteristics

Number	8016	8016	8016	8018
T (°C)	$R_{25} = 3 \text{ k}\Omega$	$R_{25} = 5 \text{ k}\Omega$	$R_{25} = 10 \text{ k}\Omega$	$R_{25} = 30 \text{ k}\Omega$
	R_T (Ω)	R_T (Ω)	R_T (Ω)	R_T (Ω)
26,0	2871,6	4786,0	9572	28737
27,0	2749,5	4582,5	9165	27531
28,0	2633,2	4388,7	8777	26385
29,0	2522,5	4204,2	8408	25290
30,0	2417,1	4028,5	8057	24249
31,0	2316,5	3860,9	7722	23256
32,0	2220,7	3701,2	7402	22305
33,0	2129,4	3549,1	7098	21402
34,0	2042,4	3404,0	6808	20538
35,0	1959,4	3265,7	6531	19716
36,0	1880,2	3133,7	6267	18927
37,0	1804,7	3007,8	6016	18177
38,0	1732,6	2887,7	5775	17460
39,0	1663,8	2773,0	5546	16773
40,0	1598,1	2663,5	5327	16119
41,0	1535,2	2558,7	5117	15495
42,0	1475,2	2458,7	4917	14895
43,0	1417,8	2363,1	4726	14325
44,0	1363,0	2271,7	4543	13776
45,0	1310,6	2184,4	4369	13254
46,0	1260,5	2100,8	4202	12750
47,0	1212,6	2021,0	4042	12273
48,0	1166,7	1944,6	3889	11811
49,0	1122,9	1871,5	3743	11373
50,0	1080,9	1801,5	3603	10950
51,0	1040,6	1734,4	3469	10545
52,0	1002,0	1670,1	3340	10158
53,0	965,12	1608,5	3217	9786,0
54,0	929,75	1549,6	3099	9429,0
55,0	895,86	1493,1	2986	9090,0
56,0	863,40	1439,0	2878	8760,0
57,0	832,28	1387,1	2774	8448,0
58,0	802,44	1337,4	2675	8148,0
59,0	773,84	1289,7	2579	7857,0
60,0	746,40	1244,0	2488	7581,0
61,0	720,07	1200,1	2400	7314,0
62,0	694,81	1158,0	2316	7059,0
63,0	670,56	1117,6	2235	6818,0
64,0	647,27	1078,8	2158	6579,0
65,0	624,91	1041,5	2083	6354,0

R/T characteristics

Number	8016	8016	8016	8018
<i>T</i> (°C)	$R_{25} = 3 \text{ k}\Omega$	$R_{25} = 5 \text{ k}\Omega$	$R_{25} = 10 \text{ k}\Omega$	$R_{25} = 30 \text{ k}\Omega$
	$R_T (\Omega)$	$R_T (\Omega)$	$R_T (\Omega)$	$R_T (\Omega)$
66,0	603,43	1005,7	2011	6135,0
67,0	582,80	971,33	1943	5928,0
68,0	562,97	938,29	1877	5727,0
69,0	543,92	906,53	1813	5535,0
70,0	525,60	876,00	1752	5349,0
75,0	444,41	740,69	1481	4524,0
80,0	377,40	629,00	1258	3840,0
85,0	321,70	536,17	1072	3273,0
90,0	275,31	458,85	917,7	2799,0
95,0	236,56	394,26	788,5	2404,8
100,0	204,00	340,00	680,0	2073,0
105,0	176,58	294,30	588,6	1792,2
110,0	153,36	255,60	511,2	1554,9
115,0	133,62	222,70	445,4	1353,6
120,0	116,79	194,65	389,3	1182,0
125,0	102,51	170,85	341,7	1035,0
130,0	90,270	150,45	300,9	909,60
135,0	79,633	132,72	265,4	801,60
140,0	70,440	117,40	234,8	708,30
145,0	62,496	104,16	208,3	627,30
150,0	55,590	92,650	185,3	557,10
155,0	49,604	82,674	165,3	—

Resistance and temperature tolerances versus temperature ($\Delta T = 0,2$ K)

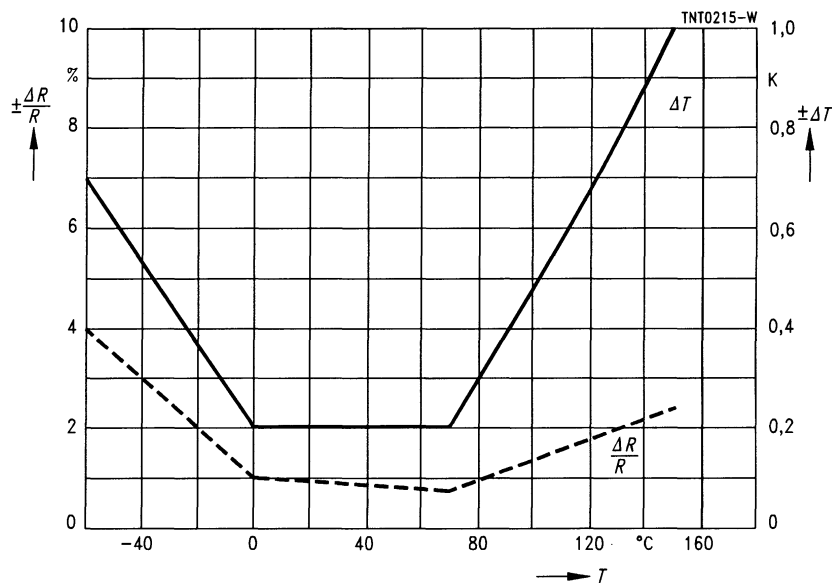

Resistance and temperature tolerances versus temperature ($\Delta T = 0,5$ K)

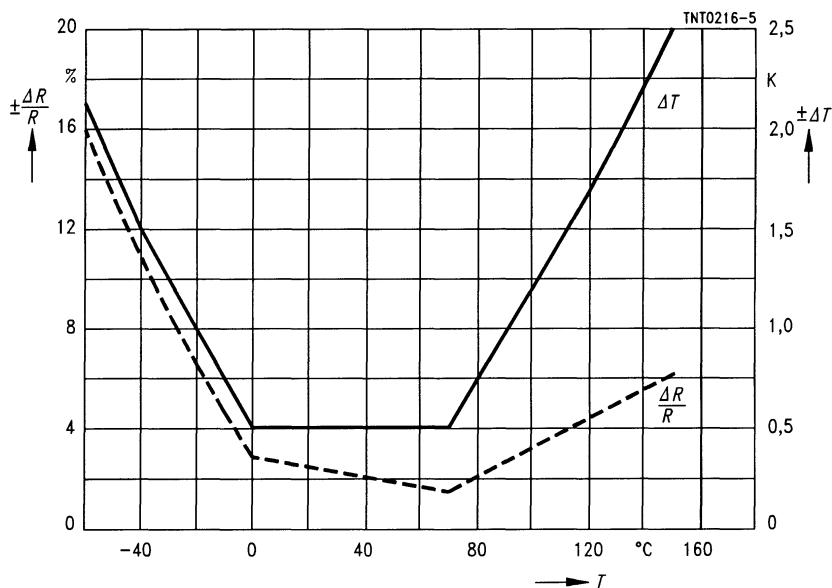

B57863
S 863

Reliability data

Test	Standard	Test conditions	$\Delta R_{25}/R_{25}$ (typical)	Remarks
Storage in dry heat	IEC 68-2-2	Storage at upper category temperature T : 155 °C t : 1000 h	< 1 %	No visible damage
Storage in damp heat, steady state	IEC 68-2-3	Temperature of air: 40 °C Relative humidity of air: 93 % Duration: 56 days	< 1 %	No visible damage
Rapid temperature cycling	IEC 68-2-14	Lower test temperature: -55 °C Upper test temperature: 155 °C Number of cycles: 5	< 0,5 %	No visible damage
Long-term stability (empirical value)		Temperature: + 70 °C Duration: 10 000 h	< 2 %	No visible damage

Applications

- Heating and air conditioning systems
- Industrial electronics
- Automotive electronics

Features

- Fast response
- Accuracy of 0,2 K between 0 °C and 70 °C
- Excellent long-term stability
- Uni curve sensor
- Epoxy resin encapsulation
- Silver-plated MONEL leads

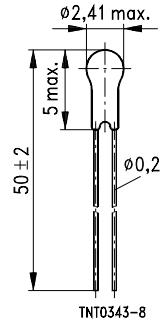

Dimensions in mm
Approx. weight 60 mg

Climatic category (IEC 68-1)		55/155/56	
Max. power at 25 °C	P_{25}	60	mW
Temperature tolerance (0 ... 70 °C)	ΔT	$\pm 0,2, \pm 0,5$	K
Rated temperature	T_N	25	°C
Dissipation factor (in air)	δ_{th}	approx. 1	mW/K
Thermal cooling time constant (in air)	τ_c	approx. 15	s
Heat capacity	C_{th}	approx. 15	mJ/K

Type	R_{25} Ω	No. of R/T characteristic	$B_{25/100}$ K	Ordering code
S 869/3 k/+ 40	3 k	8016	3988	B57869-S302-+40
S 869/5 k/+ 40	5 k	8016	3988	B57869-S502-+40
S 869/10 k/+40	10 k	8016	3988	B57869-S103-+40
S 869/30 k/+40	30 k	8018	3964	B57869-S303-+40

+ : F for $\Delta T = 0,2$ K
G for $\Delta T = 0,5$ K

For R/T characteristics, resistance and temperature tolerance curves and reliability data refer to S863, page 76 ff.

Applications

- Temperature compensation (chassis mounting)
- Temperature measurement (chassis mounting)
- Temperature control (chassis mounting)

Features

- Cost-effective
- Good thermal coupling through screw-type case (thread M3)
- Electrically isolated aluminum case
 $R_{is} > 100 \text{ M}\Omega$ ($V = 100 \text{ V dc}$)
 $V_{is} = 2500 \text{ V}$ (test duration: 1 s)
- Tinned copper leads

Options

Closer resistance tolerance available on request

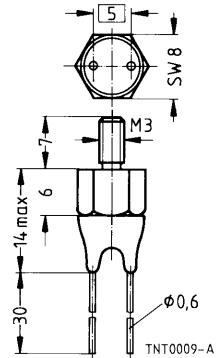

Dimensions in mm
Approx. weight 1 g

Climatic category (IEC 68-1)		55/125/56	
Max. power at 25 °C	P_{25}	450	mW
Resistance tolerance	$\Delta R/R_N$	± 10 %	
Rated temperature	T_N	25	°C
B value tolerance	$\Delta B/B$	± 3 %	
Dissipation factor (in air)	δ_{th}	approx. 9	mW/K
Dissipation factor (on chassis)	δ_{th}	approx. 20	mW/K
Thermal cooling time constant (in air)	τ_c	approx. 75	s
Thermal cooling time constant (on chassis)	τ_c	approx. 15	s
Torque		approx. 0,5	Nm

Type	R_{25} Ω	No. of R/T characteristic	$B_{25/100}$ K	Ordering code
K 45/1 k/K	1 k	1011	3730	B57045-K102-K
K 45/2,2 k/K	2,2 k	1013	3900	B57045-K222-K
K 45/4,7 k/K	4,7 k	4001	3950	B57045-K472-K
K 45/6,8 k/K	6,8 k	2903	4200	B57045-K682-K
K 45/10 k/K	10,0 k	2904	4300	B57045-K103-K

Type	R_{25} Ω	No. of R/T characteristic	$B_{25/100}$ K	Ordering code
K 45/33 k/K	33 k	1012	4300	B57045-K333-K
K 45/47 k/K	47 k	4003	4450	B57045-K473-K
K 45/68 k/K	68 k	2005	4600	B57045-K683-K
K 45/100 k/K	100 k	2005	4600	B57045-K104-K
K 45/150 k/K	150 k	2005	4600	B57045-K154-K

Reliability data

Test	Standard	Test conditions	$\Delta R_{25}/R_{25}$ (typical)	Remarks
Storage in dry heat	IEC 68-2-2	Storage at upper category temperature T : 125 °C t : 1000 h	< 3 %	No visible damage
Storage in damp heat, steady state	IEC 68-2-3	Temperature of air: 40 °C Relative humidity of air: 93 % Duration: 56 days	< 3 %	No visible damage
Rapid temperature cycling	IEC 68-2-14	Lower test temperature: -55 °C Upper test temperature: 125 °C Number of cycles: 5	< 3 %	No visible damage
Endurance		P_{max} : 450 mW Duration: 1000 h	< 3 %	No visible damage
Long-term stability (empirical value)		Temperature: 125 °C Duration: 10 000 h	< 5 %	No visible damage

Applications

- Surface temperature measurement, e.g. on housings and pipes

Features

- High accuracy
- Easy mounting
- Good thermal coupling through metal tag
- Thermistor encapsulated in metal-tag case
- PTFE-insulated leads of nickel wire, AWG 30, \varnothing 0,25 mm

Options

Alternative resistance ratings, rated temperatures, tolerances and lead lengths available on request

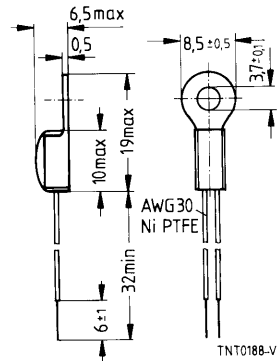

Dimensions in mm
Approx. weight 0,8 g

Climatic category (IEC 68-1)		55/125/56	
Max. power at 25 °C	P_{25}	150	mW
Resistance tolerance	$\Delta R/R_N$	± 2 %	
Rated temperature	T_N	25	°C
B value tolerance	$\Delta B/B$	± 1 %	
Dissipation factor (in air)	$\delta_{th}^{(1)}$	approx. 2,6	mW/K
Thermal cooling time constant (in air)	$\tau_c^{(1)}$	approx. 28	s
Heat capacity	$C_{th}^{(1)}$	approx. 73	mJ/K
Test voltage ($t = 1$ s)		1	kV

Type	R_{25} Ω	No. of R/T characteristic	$B_{25/100}$ K	Ordering code
M 703/10 k/G	10 k	2001	3920	B57703-M103-G

1) Depends on mounting situation

Reliability data

Test	Standard	Test conditions	$\Delta R_{25}/R_{25}$ (typical)	Remarks
Storage in dry heat	IEC 68-2-2	Storage at upper category temperature T : 125 °C t : 1000 h	< 1 %	No visible damage
Storage in damp heat, steady state	IEC 68-2-3	Temperature of air: 40 °C Relative humidity of air: 93 % Duration: 56 days	< 0,5 %	No visible damage
Rapid temperature cycling	IEC 68-2-14	Lower test temperature: -55 °C Upper test temperature: 125 °C Number of cycles: 10	< 1 %	No visible damage
Endurance		P_{max} : 150 mW Duration: 1000 h	< 1 %	No visible damage
Long-term stability (empirical value)		Temperature: 125 °C Duration: 10 000 h	< 2 %	No visible damage

Applications

- Washing machines
- Dish washers
- Tumble-dryers
- Water boilers

Features

- Suitable for use in corrosive environments
- Compact stainless steel case
- Tab connectors (DIN 46 244/2,8 × 0,8) insulated from case
 $R_{is} > 1000 \text{ M}\Omega$ ($V = 100 \text{ V dc}$)
 $V_{is} = 2500 \text{ V dc}$ ($t = 1 \text{ s}$)
- Cost-effective ready-to-use sensor

Options

Alternative resistance ratings, rated temperatures, tolerances, 6,3 × 0,8 mm tab connectors or self-locking connectors on request

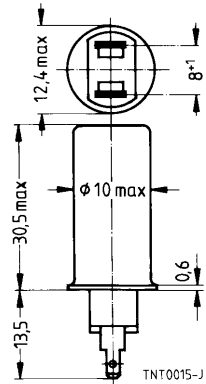

Dimensions in mm
Approx. weight 8 g

Climatic category (IEC 68-1)		10/100/56	
Max. power at 25 °C	P_{25}	500	mW
Resistance tolerance	$\Delta R/R_N$	± 2 %	
Rated temperature	T_N	80	°C
B value tolerance	$\Delta B/B$	± 1,5 %	
Dissipation factor (in water)	δ_{th}	approx. 20	mW/K
Thermal cooling time constant (in water)	τ_c	approx. 5	s
Thermal time constant	τ_a	approx. 15	s
Heat capacity	C_{th}	approx. 100	mJ/K

Type	R_0 Ω	R_{25} Ω	No. of R/T characteristic	$B_{25/100}$ K	Ordering code
K 276/12 k/A3	1704	11982	2901	3760	B57276-K123-A3

Reliability data

Test	Standard	Test conditions	$\Delta R_{25}/R_{25}$ (typical)	Remarks
Storage in dry heat	IEC 68-2-2	Storage at upper category temperature T : 100 °C t : 1000 h	< 2 %	No visible damage
Storage in damp heat, steady state	IEC 68-2-3	Temperature of air: 40 °C Relative humidity of air: 93 % Duration: 56 days	< 1 %	No visible damage
Rapid temperature cycling	IEC 68-2-14	Lower test temperature: -10 °C Upper test temperature: 100 °C Number of cycles: 10	< 1 %	No visible damage
Endurance		P_{max} : 500 mW Duration: 1000 h	< 2 %	No visible damage
Long-term stability (empirical value)		Temperature: 100 °C Duration: 10 000 h	< 3 %	No visible damage
Robustness of terminations	DIN 46 249	Pull-out force (both connectors together) $F = 50$ N	—	No visible damage

Applications

- Refrigerators
- Deep freezers

Features

- Encapsulated in compact plastic case
- Tab connectors (DIN 46 244/2,8 × 0,8) insulated from case
 $R_{is} > 1000 \text{ M}\Omega$ ($V = 100 \text{ V dc}$)
 $V_{is} = 2500 \text{ V dc}$ ($t = 1 \text{ s}$)
- Internal construction conforms to VDE 007/protection class II

Options

Alternative resistance ratings, rated temperatures, tolerances and 6,3 × 0,8 mm connectors available on request

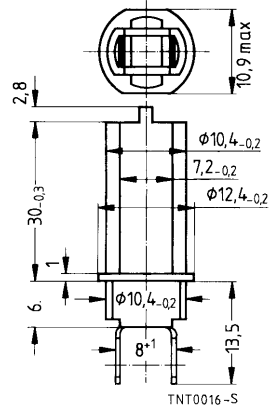

Dimensions in mm
Approx. weight 5 g

Climatic category (IEC 68-1)		40/100/56	
Max. power at 25 °C	P_{25}	420	mW
Resistance tolerance	$\Delta R/R_N$	± 2,5 %	
Rated temperature	T_N	5	°C
B value tolerance	$\Delta B/B$	± 1,5 %	
Dissipation factor (in air)	δ_{th}	approx. 12	mW/K
Thermal cooling time constant (in air)	τ_c	approx. 130	s
Heat capacity	C_{th}	approx. 1560	mJ/K

Type	R_0	R_{25}	No. of R/T characteristic	$B_{25/100}$	Ordering code
	Ω	Ω		K	
K 277/880/A1	2,0 k	883,1	1010	3530	B57277-K881-A1

Reliability data

Test	Standard	Test conditions	$\Delta R_{25}/R_{25}$ (typical)	Remarks
Storage in dry heat	IEC 68-2-2	Storage at upper category temperature T : 100 °C t : 1000 h	< 2 %	No visible damage
Storage in damp heat, steady state	IEC 68-2-3	Temperature of air: 40 °C Relative humidity of air: 93 % Duration: 56 days	< 1 %	No visible damage
Rapid temperature cycling	IEC 68-2-14	Lower test temperature: -40 °C Upper test temperature: 100 °C Number of cycles: 10	< 1 %	No visible damage
Endurance		P_{max} : 420 mW Duration: 1000 h	< 2 %	No visible damage
Long-term stability (empirical value)		Temperature: 100 °C Duration: 10 000 h	< 3 %	No visible damage
Robustness of terminations	DIN 46 249	Pull-out force (both connectors together) $F = 50$ N	—	No visible damage

Applications

- Electric motors
- Transformers

Features

- Coated thermistor disk with shrunk sleeve insulation
- PTFE-insulated wires, AWG 26

Options

Alternative resistance ratings, rated temperatures, tolerances and wire lengths available on request

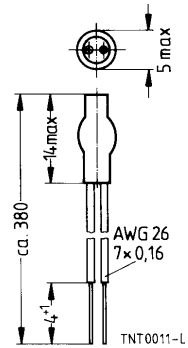

Dimensions in mm
Approx. weight 5 g

Climatic category (IEC 68-1)		55/155/56	
Max. power at 25 °C	P_{25}	200	mW
Resistance tolerance	$\Delta R/R_N$	± 10 %	
Rated temperature	T_N	100	°C
B value tolerance	$\Delta B/B$	± 1,5 %	
Dissipation factor (in air)	δ_{th}	approx. 5	mW/K
Thermal cooling time constant (in air)	τ_c	approx. 30	s
Heat capacity	C_{th}	approx. 150	mJ/K
Insulation resistance ($V = 100$ Vdc)	R_{is}	> 100	M Ω
Test voltage ($t = 1$ s)		2,5	kV

Type	R_0	R_{25}	No. of R/T characteristic	$B_{25/100}$	Ordering code
	Ω	Ω		K	
K 227/33 k/A1	1,8 k	32,762 k	2904	4300	B57227-K333-A1

Reliability data

Test	Standard	Test conditions	$\Delta R_{25}/R_{25}$ (typical)	Remarks
Storage in dry heat	IEC 68-2-2	Storage at upper category temperature T : 125 °C t : 1000 h	< 2 %	No visible damage
Storage in damp heat, steady state	IEC 68-2-3	Temperature of air: 40 °C Relative humidity of air: 93 % Duration: 56 days	< 1 %	No visible damage
Rapid temperature cycling	IEC 68-2-14	Lower test temperature: -55 °C Upper test temperature: 155 °C Number of cycles: 10	< 1 %	No visible damage
Endurance		P_{max} : 200 mW Duration: 1000 h	< 2 %	No visible damage
Long-term stability (empirical value)		Temperature: 155 °C Duration: 10 000 h	< 3 %	No visible damage

Applications

- Heating and air conditioning systems

Features

- Aluminum case
- PVC-insulated connecting cable
H03VV-F2 × 0,7 (DIN 57 281)
- With cable end sleeves
- PVC cable withstands temperatures
of up to 105 °C

Options

Alternative resistance ratings, rated temperatures, tolerances and cable lengths available on request

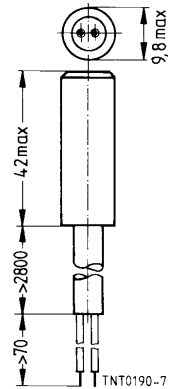

Dimensions in mm
Approx. weight 80 g

Climatic category (IEC 68-1)		10/100/56	
Max. power at 25 °C	P_{25}	380	mW
Resistance tolerance	$\Delta R/R_N$	± 2,5 %	
Rated temperature	T_N	50	°C
B value tolerance	$\Delta B/B$	± 1,5 %	
Dissipation factor (in air)	δ_{th}	approx. 11	mW/K
Thermal cooling time constant (in air)	τ_c	approx. 150	s
Heat capacity	C_{th}	approx. 1600	mJ/K

Type	R_0 Ω	R_{25} Ω	No. of R/T characteristic	$B_{25/100}$ K	Ordering code
M 831/870/A3	359,3	886,2	1008	3560	B57831-M871-A3

Reliability data

Test	Standard	Test conditions	$\Delta R_{25}/R_{25}$ (typical)	Remarks
Storage in dry heat	IEC 68-2-2	Storage at upper category temperature T : 100 °C t : 1000 h	< 1,5 %	No visible damage
Storage in damp heat, steady state	IEC 68-2-3	Temperature of air: 40 °C Relative humidity of air: 93 % Duration: 56 days	< 1 %	No visible damage
Rapid temperature cycling	IEC 68-2-14	Lower test temperature: -10 °C Upper test temperature: 100 °C Number of cycles: 10	< 1 %	No visible damage
Endurance		P_{max} : 380 mW Duration: 1000 h	< 2 %	No visible damage
Long-term stability (empirical value)		Temperature: 100 °C Duration: 10 000 h	< 2 %	No visible damage
Robustness of terminations	DIN 46 249	Pull-out force $F = 50$ N	—	No visible damage

Applications

- Refrigerators
- Deep freezers
- Air conditioning systems
- Underfloor heating

Features

- Thermistor in molded plastic case
- PVC-insulated connecting cable
- Conductor cross section: $2 \times 0,5 \text{ mm}^2$

Options

Alternative resistance ratings, rated temperatures and cable lengths available on request

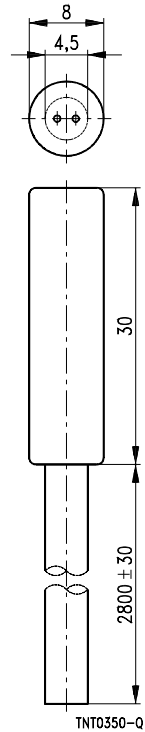

Dimensions
in mm

Climatic category		40/60/56	
Max. power at 25 °C	P_{25}	350	mW
Temperature tolerance	ΔT	± 1	K
Rated temperature	T_N	0	°C
Rated resistance	R_N	16330	Ω
B value tolerance	$\Delta B/B$	$\pm 1,5 \%$	
Dissipation factor (in air)	δ_{th}	approx. 10	mW/K
Thermal time constant (oil) ($T_1 = 0 \text{ }^\circ\text{C}$, $T_2 = 25 \text{ }^\circ\text{C}$)	τ_a	approx. 50	s
Insulation resistance	R_{is}	> 1000	M Ω

Type	R_{25} Ω	No. of R/T characteristic	$B_{25/100}$ K	Ordering code
M 2020/5 k/A1	5000	2003	3980	B57020-M2502-A1

Reliability data

Test	Test conditions	$\Delta R_{25}/R_{25}$ (typical)
Storage in water	Storage at room temperature t : 1000 h	< 1 %
Rapid temperature cycling	Lower test temperature: $-40 \text{ }^\circ\text{C}$ Upper test temperature: $60 \text{ }^\circ\text{C}$ Number of cycles: 100	< 1 %

Applications

- Air conditioning systems (automobiles)
- Heating systems (automobiles)

Features

- For temperature measurement in liquids
- Metal case with injection-molded upper section
- Compact design
- Two-wire connecting cable ($2 \times 0,75 \text{ mm}^2$) with insulating sleeve

Options

Also available with connectors and other cable lengths

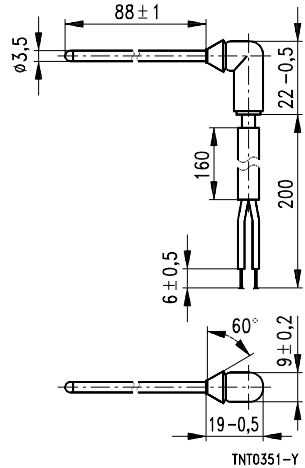

Dimensions in mm
Approx. weight 10 g

Climatic category (IEC 68-1)		40/100/56	
Max. power at 25 °C	P_{25}	100	mW
Resistance tolerance	$\Delta R/R_N$	± 2 %	
Rated temperature	T_N	0	°C
B value tolerance	$\Delta B/B$	± 1,5 %	
Dissipation factor (in air)	δ_{th}	approx. 3	mW/K
Thermal cooling time constant (in air)	τ_c	approx. 20	s
Heat capacity	C_{th}	approx. 60	mJ/K

Type	R_0	R_{25}	No. of R/T characteristic	$B_{25/100}$	Ordering code
	Ω	Ω		K	
M 912/2,7 k/A3	9,0 k	2,758 k	1106	3950	B57912-M272-A3

Reliability data

Test	Standard	Test conditions	$\Delta R_{25}/R_{25}$ (typical)	Remarks
Storage in dry heat	IEC 68-2-2	Storage at upper category temperature T : 100 °C t : 1000 h	< 1 %	No visible damage
Storage in damp heat, steady state	IEC 68-2-3	Temperature of air: 40 °C Relative humidity of air: 93 % Duration: 56 days	< 0,5 %	No visible damage
Rapid temperature cycling	IEC 68-2-14	Lower test temperature: -40 °C Upper test temperature: 100 °C Number of cycles: 10	< 1 %	No visible damage
Endurance		P_{max} : 100 mW Duration: 1000 h	< 2 %	No visible damage
Long-term stability (empirical value)		Temperature: 100 °C Duration: 10 000 h	< 2 %	No visible damage
Robustness of terminations	DIN 46 249	Pull-out force $F = 100$ N	—	No visible damage

Applications

- Heating systems
- Water boilers

Features

- For temperature measurement in liquids
- Stainless steel case (a); the NTC is incorporated in the injection-molded plastic base (c)
- Tab connectors 2,8 × 0,8
- With O sealing ring (b)
- Fast response

Options

Cable connectors, customized case styles, alternative resistance ratings, rated temperatures and tolerances available on request

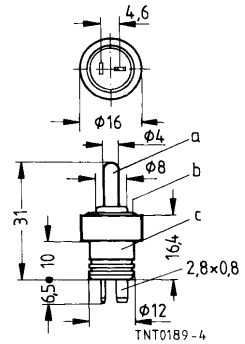

Dimensions in mm
Approx. weight 4,5 g

Climatic category (IEC 68-1)		25/100/56	
Max. power at 25 °C	P_{25}	100	mW
Resistance tolerance	$\Delta R/R_N$	± 2 %	
Rated temperature	T_N	25	°C
B value tolerance	$\Delta B/B$	± 1,5 %	
Dissipation factor (in air)	δ_{th}	approx. 9	mW/K
Thermal time constant (in water)	τ_a	approx. 2,5	s
Heat capacity	C_{th}	approx. 20	mJ/K

Type	R_{25} Ω	No. of R/T characteristic	$B_{25/100}$ K	Ordering code
Z 10/10 k/G	10 k	2001	3920	B57010-Z103-G

Reliability data

Test	Standard	Test conditions	$\Delta R_{25}/R_{25}$ (typical)	Remarks
Storage in dry heat	IEC 68-2-2	Storage at upper category temperature T : 100 °C t : 1000 h	< 1 %	No visible damage
Storage in damp heat, steady state	IEC 68-2-3	Temperature of air: 40 °C Relative humidity of air: 93 % Duration: 56 days	< 0,5 %	No visible damage
Rapid temperature cycling	IEC 68-2-14	Lower test temperature: -25 °C Upper test temperature: 100 °C Number of cycles: 10	< 1 %	No visible damage
Endurance		P_{max} : 100 mW Duration: 1000 h	< 2 %	No visible damage
Long-term stability (empirical value)		Temperature: 100 °C Duration: 10 000 h	< 2 %	No visible damage
Robustness of terminations	DIN 46 249	Pull-out force (both connectors together) $F = 50$ N	—	No visible damage

Applications

- Switch-mode power supplies

Features

- Useable in series connections up to 265 V_{rms}
- Coated thermistor disk
- Cost-effective NTC for low-power applications
- Kinked leads of tinned, nickel-plated copper wire
- Small size
- Available on tape
- UL approval (E69802)

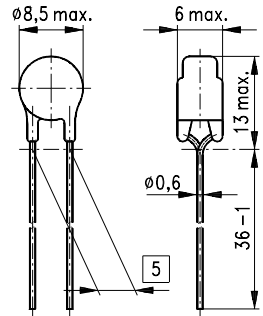

Dimensions in mm
Approx. weight 0,6 g

Lower/upper category temperature		- 55/+ 170	°C
Max. power at 25 °C	P_{max}	1,4	W
Resistance tolerance	$\Delta R/R_N$	± 20 %	
Rated temperature	T_N	25	°C
B value tolerance	$\Delta B/B$	± 3 %	
Dissipation factor (in air)	δ_{th}	approx. 8	mW/K
Thermal cooling time constant (in air)	τ_c	approx. 30	s
Heat capacity	C_{th}	approx. 240	mJ/K

Type	R_{25}	I_{max}	No. of R/T char- acteristic	$B_{25/100}$	C_T ¹⁾	Parameters for $R(I)$ ¹⁾		Ordering code
	Ω	(0 ... 65 °C) A				k	n	
S 153/4,7/M	4,7	3,0	1202	2800	100	0,644	- 1,30	B57153-S479-M
S 153/10/M	10	2,0	1202	2800	100	0,838	- 1,30	B57153-S100-M
S 153/15/M	15	1,8	1203	2900	100	0,934	- 1,32	B57153-S150-M
S 153/33/M	33	1,3	1302	3000	100	1,180	- 1,33	B57153-S330-M

1) For details on the capacitance C_T as well as on the parameters k and n refer to [pages 38–40](#).

Not for new design (replaced by S 237)

Applications

- Switch-mode power supplies
- Soft-start motors, e.g. in vacuum cleaners

Features

- Useable in series connections up to 265 V_{rms}
- Coated thermistor disk for line applications
- Kinked leads of tinned, nickel-plated copper wire
- Wide resistance range
- Available on tape
- UL approval (E69802)

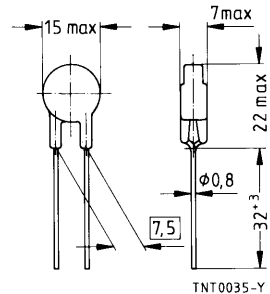

Dimensions in mm
Approx. weight 2 g

Options

Resistance tolerance < 20 % available on request

Lower/upper category temperature		- 55/+ 170	°C
Max. power at 25 °C	P_{max}	3,6	W
Resistance tolerance	$\Delta R/R_N$	± 20 %	
Rated temperature	T_N	25	°C
B value tolerance	$\Delta B/B$	± 3 %	
Dissipation factor (in air)	δ_{th}	approx. 17	mW/K
Thermal cooling time constant (in air)	τ_c	approx. 90	s
Heat capacity	C_{th}	approx. 1530	mJ/K

Type	R_{25} Ω	I_{max} (0 ... 65 °C) A	No. of R/T char- acteristic	$B_{25/100}$ K	C_T 1) μF	Parameters for $R(I)$ 1)		Ordering code
						k	n	
S 234/1,0/M	1,0	11,5	1201	2600	700	0,622	- 1,27	B57234-S109-M
S 234/2,2/M	2,2	9,0	1202	2800	700	0,806	- 1,30	B57234-S229-M
S 234/2,5/M	2,5	8,4	1202	2800	700	0,843	- 1,30	B57234-S259-M
S 234/4,7/M	4,7	6,6	1203	2900	700	1,03	- 1,32	B57234-S479-M
S 234/5,0/M	5,0	6,4	1203	2900	700	1,05	- 1,32	B57234-S509-M
S 234/7,0/M	7,0	6,0	1302	3000	700	1,16	- 1,33	B57234-S709-M
S 234/10/M	10	5,0	1308	3060	700	1,29	- 1,34	B57234-S100-M
S 234/15/M	15	4,0	1302	3000	700	1,49	- 1,33	B57234-S150-M
S 234/22/M	22	4,0	1304	3300	700	1,57	- 1,37	B57234-S220-M
S 234/33/M	33	3,3	1304	3300	900	1,78	- 1,37	B57234-S330-M
S 234/40/M	40	3,4	1306	3450	400	1,82	- 1,38	B57234-S400-M
S 234/60/M	60	4,0	1103	4000	400	1,77	- 1,44	B57234-S600-M

1) For details on the capacitance C_T as well as on the parameters k and n refer to [pages 38–40](#).

Applications

- Switch-mode power supplies

Features

- Useable in series connections up to 265 V_{rms}
- Coated thermistor disk
- Kinked leads of tinned, nickel-plated copper wire
- Wide resistance range
- Small space requirement
- Cost-effective
- Available on tape
- UL approval (E69802)

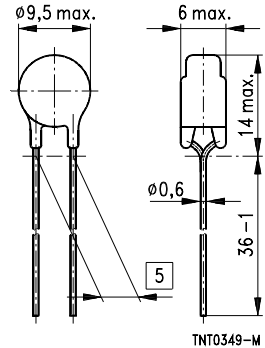

Options

Resistance tolerance < 20 % available

Dimensions in mm
Approx. weight 0,8 g

Lower/upper category temperature		- 55/+ 170	°C
Max. power at 25 °C	P_{max}	1,8	W
Resistance tolerance	$\Delta R/R_N$	± 20 %	
Rated temperature	T_N	25	°C
B value tolerance	$\Delta B/B$	± 3 %	
Dissipation factor (in air)	δ_{th}	approx. 9	mW/K
Thermal cooling time constant (in air)	τ_c	approx. 60	s
Heat capacity	C_{th}	approx. 540	mJ/K

Type	R_{25} Ω	I_{max} (0 ... 65 °C) A	No. of R/T char- acteristic	$B_{25/100}$ K	C_T ¹⁾ μF	Parameters for $R(I)$ ¹⁾		Ordering code
						k	n	
S 235/5,0/M	5,0	4,2	1202	2800	200	0,710	- 1,30	B57235-S509-M
S 235/6,0/M	6,0	4,0	1202	2800	200	0,757	- 1,30	B57235-S609-M
S 235/8,0/M	8,0	3,5	1203	2900	200	0,814	- 1,32	B57235-S809-M
S 235/10/M	10,0	3,0	1203	2900	200	0,879	- 1,32	B57235-S100-M

1) For details on the capacitance C_T as well as on the parameters k and n refer to [pages 38–40](#).

Applications

- Switch-mode power supplies

Features

- Useable in series connections up to 265 V_{rms}
- Coated thermistor disk
- Kinked leads of tinned, nickel-plated copper wire
- Wide resistance range
- Available on tape
- UL approval (E69802)

Options

Resistance tolerance < 20 % available on request

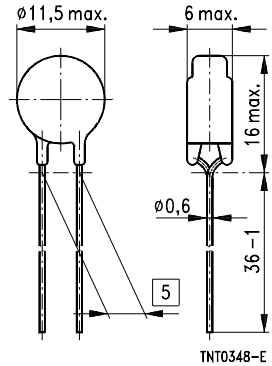

Dimensions in mm
Approx. weight 1 g

Lower/upper category temperature		- 55/+ 170	°C
Max. power at 25 °C	P_{max}	2,1	W
Resistance tolerance	$\Delta R/R_N$	± 20 %	
Rated temperature	T_N	25	°C
B value tolerance	$\Delta B/B$	± 3 %	
Dissipation factor (in air)	δ_{th}	approx. 10	mW/K
Thermal cooling time constant (in air)	τ_c	approx. 70	s
Heat capacity	C_{th}	approx. 700	mJ/K

Type	R_{25} Ω	I_{max} (0 ... 65 °C) A	No. of R/T char- acteristic	$B_{25/100}$ K	C_T ¹⁾ μF	Parameters for $R(I)$ ¹⁾		Ordering code
						k	n	
S 236/2,5/M	2,5	5,5	1201	2600	200	0,621	- 1,27	B57236-S259-M
S 236/5,0/M	5,0	4,5	1202	2800	300	0,761	- 1,30	B57236-S509-M
S 236/10/M	10	3,5	1203	2900	300	0,942	- 1,32	B57236-S100-M
S 236/12/M	12	3,2	1203	2900	300	1,00	- 1,32	B57236-S120-M
S 236/16/M	16	2,9	1207	2965	300	1,08	- 1,33	B57236-S160-M
S 236/20/M	20	2,8	1208	3065	300	1,13	- 1,34	B57236-S200-M
S 236/25/M	25	2,5	1208	3065	300	1,22	- 1,34	B57236-S250-M
S 236/50/M	50	1,9	1209	3165	300	1,44	- 1,38	B57236-S500-M
S 236/80/M	80	1,6	1304	3300	400	1,64	- 1,37	B57236-S800-M

1) For details on the capacitance C_T as well as on the parameters k and n refer to [pages 38–40](#).

Replacement for S 234

Applications

- Switch-mode power supplies
- Soft-start motors, e.g. in vacuum cleaners

Features

- Useable in series connections up to $265 V_{rms}$
- Coated thermistor disk
- Kinked leads of tinned, nickel-plated copper wire
- Wide resistance range
- Available on tape
- UL approval (E69802)

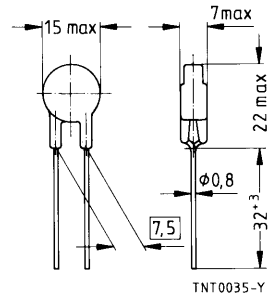

Dimensions in mm
Approx. weight 2 g

Options

Resistance tolerance < 20 % available on request

Lower/upper category temperature		- 55/+ 170	°C
Max. power at 25 °C		3,1	W
Resistance tolerance	P_{max} $\Delta R/R_N$	± 20 %	
Rated temperature	T_N	25	°C
Dissipation factor (in air)	δ_{th}	approx. 17	mW/K
Thermal cooling time constant (in air)	τ_c	approx. 90	s
Heat capacity	C_{th}	approx. 1530	mJ/K

Type	R_{25}	I_{max} (25 °C)	R_{Min}	C_T 1)	Parameters for $R(I)$ 1)		Ordering code
	Ω	A	Ω	μF	k	n	
S 237/1,0/M	1,0	9,0	0,04	700	0,622	- 1,27	B57237-S109-M
S 237/2,2/M	2,2	7,0	0,06	700	0,806	- 1,30	B57237-S229-M
S 237/2,5/M	2,5	6,5	0,07	700	0,843	- 1,30	B57237-S259-M
S 237/4,7/M	4,7	5,1	0,12	700	1,03	- 1,32	B57237-S479-M
S 237/5,0/M	5,0	5,0	0,12	700	1,05	- 1,32	B57237-S509-M
S 237/7,0/M	7,0	4,2	0,17	700	1,16	- 1,33	B57237-S709-M
S 237/10/M	10	3,7	0,22	700	1,29	- 1,34	B57237-S100-M
S 237/15/M	15	3,0	0,34	700	1,49	- 1,33	B57237-S150-M
S 237/22/M	22	2,8	0,39	700	1,57	- 1,37	B57237-S220-M
S 237/33/M	33	2,5	0,50	900	1,78	- 1,37	B57237-S330-M

1) For details on the capacitance C_T as well as on the parameters k and n refer to [pages 38–40](#).

Applications

- Switch-mode power supplies
- Soft-start motors, e.g. in vacuum cleaners

Features

- Useable in series connections up to 265 V_{rms}
- Coated thermistor disk
- Kinked leads of tinned, nickel-plated copper wire
- Wide resistance range
- Available on tape
- UL approval (E69802)

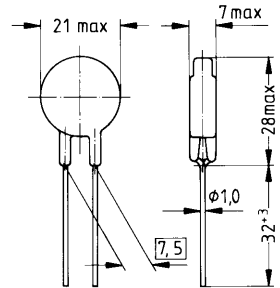

TNT0036-7

Options

Resistance tolerance < 20 % available on request

Dimensions in mm
Approx. weight 4 g

Lower/upper category temperature		- 55/+ 170	°C
Max. power at 25 °C	P_{max}	5,1	W
Resistance tolerance	$\Delta R/R_N$	± 20 %	
Rated temperature	T_N	25	°C
B value tolerance	$\Delta B/B$	± 3 %	
Dissipation factor (in air)	δ_{th}	approx. 24	mW/K
Thermal cooling time constant (in air)	τ_c	approx. 100	s
Heat capacity	C_{th}	approx. 2400	mJ/K

Type	R_{25} Ω	I_{max} (0 ... 65 °C) A	No. of R/T char- acteristic	$B_{25/100}$ K	C_T ¹⁾ μF	Parameters für $R(I)$ ¹⁾		Ordering code
						k	n	
S 364/1,0/M	1,0	16,0	1202	2800	1000	0,766	- 1,30	B57364-S109-M
S 364/2,0/M	2,0	12,0	1203	2900	1000	0,966	- 1,32	B57364-S209-M
S 364/2,5/M	2,5	11,0	1203	2900	1000	1,04	- 1,32	B57364-S259-M
S 364/4,0/M	4,0	9,5	1308	3060	1000	1,20	- 1,34	B57364-S409-M
S 364/5,0/M	5,0	8,5	1308	3060	1000	1,29	- 1,34	B57364-S509-M
S 364/10/M	10	7,5	1304	3300	1000	1,55	- 1,37	B57364-S100-M

1) For details on the capacitance C_T as well as on the parameters k and n refer to [pages 38–40](#).

Applications

- Switch-mode power supplies
- Soft-start motors, e.g. in vacuum cleaners

Features

- Useable in series connections up to 265 V_{rms}
- Coated thermistor disk
- Kinked leads of tinned, nickel-plated copper wire
- High energy absorption capability

Options

Additional resistance ratings and tolerances < 20 % available on request

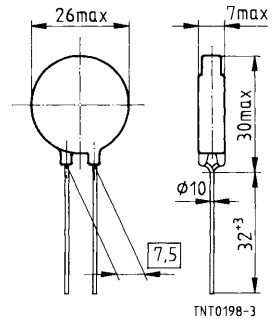

Dimensions in mm
Approx. weight 9 g

Lower/upper category temperature		- 55/+ 170	°C
Max. power at 25 °C	P_{max}	6,7	W
Resistance tolerance	$\Delta R/R_N$	± 20 %	
Rated temperature	T_N	25	°C
B value tolerance	$\Delta B/B$	± 3 %	
Dissipation factor (in air)	δ_{th}	approx. 30	mW/K
Thermal cooling time constant (in air)	τ_c	approx. 130	s
Heat capacity	C_{th}	approx. 3900	mJ/K

Type	R_{25} Ω	I_{max} (0 ... 65 °C) A	No. of R/T char- acteristic	$B_{25/100}$ K	C_T 1) μF	Parameters für $R(I)$ 1) k n		Ordering code
S 464/1,0/M	1,0	20	1202	2800	2500	0,886	- 1,30	B57464-S109-M

1) For details on the capacitance C_T as well as on the parameters k and n refer to [pages 38–40](#).

Inrush Current Limiting

S 153 ... S 464

Reliability data – ICL

Test	Standard	Test conditions	$\Delta R_{25}/R_{25}$ (typical)	Remarks
Storage in dry heat	IEC 68-2-2	Storage at upper category temperature $T: 170\text{ °C}$ $t: 1000\text{ h}$	< 10 %	No visible damage
Storage in damp heat, steady state	IEC 68-2-3	Temperature of air: 40 °C Relative humidity of air: 93 % Duration: 21 days	< 5 %	No visible damage
Rapid temperature cycling	IEC 68-2-14	Lower test temperature: -55 °C Upper test temperature: 170 °C Number of cycles: 5	< 10 %	No visible damage
Endurance		$I = I_{\max}$ Duration: 1000 h	< 10 %	No visible damage
Cyclic endurance		$I = I_{\max}$, 1000 cycles On-time = 1 min Cooling time = 6 min	< 10 %	No visible damage

Standardized R/T Characteristics

1 Introduction

The R/T characteristics tabulated in the following have been standardized for the resistance value at 25 °C. The actual resistance values of a particular NTC thermistor are obtained by multiplying the ratio R_T/R_{25} (tabulated value) by the resistance value at 25 °C (specified in the data sheets).

$$R_T = \frac{R_T}{R_{25}} \cdot R_{25} \quad (1)$$

Resistance values at intermediate temperatures within the range of the subsequent temperature interval can be calculated by means of the temperature coefficient α .

α is inserted in the following equation:

$$R_T = R_{T_x} \cdot \exp \left[\frac{\alpha_x}{100} \cdot (T_x + 273,15)^2 \cdot \left(\frac{1}{T + 273,15} - \frac{1}{T_x + 273,15} \right) \right] \quad (2)$$

R_T	Resistance value at temperature T
R_{T_x}	Resistance value at the beginning of the relevant temperature interval
T_x	Temperature in °C at the beginning of the relevant temperature interval
T	Temperature of interest in °C ($T_x < T < T_{x+1}$)
α_x	Temperature coefficient at temperature T_x

Example:

Given:	Curve 1006
	$R_{25} = 4,7 \text{ k}\Omega$
	$\alpha_5 = 4,4$
Unknown:	Resistance at 7 °C (R_7)

a) Calculation of the resistance value at the beginning of the relevant temperature interval ($T_x = 5 \text{ °C}$):

$$R_{T_x} = R_5 = 2,2739 \cdot 4,7 \text{ k}\Omega = 10,6873 \text{ k}\Omega$$

b) Substituting this value into equation (2) yields:

$$R_7 = R_5 \cdot \exp \left[\frac{\alpha_5}{100} \cdot (5 + 273,15)^2 \cdot \left(\frac{1}{7 + 273,15} - \frac{1}{5 + 273,15} \right) \right]$$

$$R_7 = 10,6873 \text{ k}\Omega \cdot \exp \left[\frac{4,4}{100} \cdot 278,15^2 \cdot \left(\frac{1}{280,15} - \frac{1}{278,15} \right) \right]$$

$$R_7 = 10,6873 \text{ k}\Omega \cdot \exp[-0,08737] = 10,6873 \cdot 0,9163$$

$$R_7 = 9,7932 \text{ k}\Omega$$

Standardized R/T Characteristics

2 Resistance tolerance

The tolerance range of resistance can be calculated proceeding from the rated temperature and the corresponding rated resistance tolerance (see also chapter 3.1.3).

In practice, the following equation is used:

$$\left| \frac{\Delta R_T}{R_T} \right| = \left| \frac{\Delta R_N}{R_N} \right| + \left| \frac{\Delta B}{B} \cdot B \cdot \left(\frac{1}{T} - \frac{1}{T_N} \right) \right| \quad (3)$$

$|\Delta R_T/R_T|$ Maximum spread of resistance at temperature T in %

$|\Delta R_N/R_N|$ Rated tolerance of resistance value at temperature T_N (given in data sheet) in %

$|\Delta B/B|$ Rated tolerance of B value (given in data sheet) in %

B $B_{25/100}$ value (given in data sheet) in K

T, T_N Temperatures in K

Example:

Given: NTC B57820-M561-A5

Curve 1009

$B_{25/100} = 3930$

B value tolerance $|\Delta B/B| = 1,5 \%$

Rated temperature $T_N = 100 \text{ }^\circ\text{C}$

Rated resistance $R_N = R_{100} = 39,6 \text{ } \Omega$

Resistance tolerance at $100 \text{ }^\circ\text{C}$ $|\Delta R_N/R_N| = 5 \%$

Unknown: Resistance value at $35 \text{ }^\circ\text{C}$ ($R_T = R_{35}$)

Resistance tolerance at $35 \text{ }^\circ\text{C}$ ($|\Delta R_T/R_T| = |\Delta R_{35}/R_{35}|$)

a) Calculation of reference resistance R_{25} (required for working with the standardized R/T curve; if the rated temperature is $25 \text{ }^\circ\text{C}$ this step is omitted) by means of equation (1):

$$R_{100} = \frac{R_{100}}{R_{25}} \cdot R_{25} \qquad R_{25} = \left(\frac{R_{100}}{R_{25}} \right)^{-1} \cdot R_{100}$$

$$R_{25} = \frac{1}{0,070690} \cdot 39,6 \text{ } \Omega = 560,2 \text{ } \Omega$$

(0,070690 = Factor of curve 1009 at $100 \text{ }^\circ\text{C}$)

b) Calculation of resistance value at $35 \text{ }^\circ\text{C}$:

$$R_{35} = \frac{R_{35}}{R_{25}} \cdot R_{25} = 0,65726 \cdot 560,2 \text{ } \Omega = 368,2 \text{ } \Omega$$

(0,65726 = Factor of curve at $35 \text{ }^\circ\text{C}$)

c) Calculation of resistance tolerance by means of equation (3):

$$\begin{aligned} \left| \frac{\Delta R_{35}}{R_{35}} \right| &= \left[5 + 1,5 \cdot 3930 \cdot \left(\frac{1}{(35 + 273,15)} - \frac{1}{(100 + 273,15)} \right) \right] \% \\ &= \left[5 + 5895 \cdot \left| \frac{1}{308,15} - \frac{1}{373,15} \right| \right] \% \\ &= (5 + 5895 \cdot 0,00056529) \% \\ &= 5,0 \% + 3,3 \% = 8,3 \% \end{aligned}$$

If the R/T characteristics are computer-stored, the resistance tolerances for all temperatures can be easily determined by an appropriate calculation program.

3 Temperature tolerance

With given resistance tolerance, the temperature tolerance is determined as follows:

$$\Delta T = \frac{1}{\alpha} \cdot \frac{\Delta R_T}{R_T} \tag{4}$$

α Temperature coefficient at T in %/K (see R/T characteristic)
 $|\Delta R_T/R_T|$ Resistance tolerance in % at T

The following applies to the example given under point 2:

$$\Delta T(100 \text{ }^\circ\text{C}) = \frac{1}{2,9} \cdot 5 \text{ K} = 1,72 \text{ K}$$

$$\Delta T(35 \text{ }^\circ\text{C}) = \frac{1}{4,1} \cdot 8,3 \text{ K} = 2,02 \text{ K}$$

The calculation mode given here is to be regarded as an approximation of actual conditions (B value temperature-dependent, tolerances symmetrical); nevertheless, the results obtained are sufficiently accurate for practical applications.

Standardized R/T Characteristics

4 Characteristics

Number	1006		1008		1009		1010	
	$B_{25/100} = 3550 \text{ K}$		$B_{25/100} = 3560 \text{ K}$		$B_{25/100} = 3930 \text{ K}$		$B_{25/100} = 3530 \text{ K}$	
T (°C)	R_T/R_{25}	α (%/K)	R_T/R_{25}	α (%/K)	R_T/R_{25}	α (%/K)	R_T/R_{25}	α (%/K)
-55,0	48,503	5,8	53,104	6,1	85,423	7,0	52,826	6,4
-50,0	36,524	5,7	39,318	6,0	60,781	6,8	38,643	6,1
-45,0	27,639	5,6	29,325	5,8	43,650	6,6	28,574	5,9
-40,0	21,021	5,5	22,030	5,7	31,629	6,4	21,346	5,7
-35,0	16,069	5,4	16,666	5,5	23,118	6,2	16,100	5,5
-30,0	12,348	5,3	12,696	5,4	17,040	6,1	12,256	5,4
-25,0	9,5313	5,1	9,7251	5,2	12,649	5,9	9,4071	5,2
-20,0	7,4185	5,1	7,5171	5,1	9,4864	5,8	7,2862	5,0
-15,0	5,7780	4,9	5,8353	4,9	7,1545	5,6	5,6835	4,9
-10,0	4,5373	4,9	4,5686	4,8	5,4479	5,4	4,4698	4,7
- 5,0	3,5762	4,7	3,6050	4,7	4,1732	5,2	3,5385	4,6
0,0	2,8409	4,5	2,8665	4,5	3,2256	5,1	2,8222	4,5
5,0	2,2739	4,4	2,2907	4,4	2,5147	4,9	2,2649	4,3
10,0	1,8330	4,2	1,8438	4,3	1,9763	4,8	1,8300	4,2
15,0	1,4883	4,1	1,4920	4,1	1,5649	4,6	1,4872	4,1
20,0	1,2160	4,0	1,2154	4,0	1,2481	4,5	1,2161	4,0
25,0	1,0000	3,9	1,0000	3,9	1,0000	4,3	1,0000	3,9
30,0	0,82627	3,8	0,82976	3,8	0,80956	4,2	0,82677	3,8
35,0	0,68600	3,7	0,68635	3,7	0,65726	4,1	0,68708	3,6
40,0	0,57254	3,6	0,57103	3,6	0,53697	4,0	0,57401	3,5
45,0	0,48050	3,5	0,48015	3,5	0,44169	3,9	0,48181	3,5
50,0	0,40514	3,4	0,40545	3,4	0,36534	3,8	0,40638	3,4
55,0	0,34213	3,3	0,34170	3,3	0,30327	3,7	0,34427	3,3
60,0	0,29036	3,2	0,28952	3,2	0,25313	3,5	0,29296	3,2
65,0	0,24838	3,1	0,24714	3,1	0,21271	3,4	0,25035	3,1
70,0	0,21342	3,0	0,21183	3,1	0,17962	3,4	0,21478	3,0
75,0	0,18371	3,0	0,18194	3,0	0,15219	3,3	0,18501	2,9
80,0	0,15873	2,9	0,15680	2,9	0,12949	3,2	0,15995	2,9
85,0	0,13756	2,8	0,13592	2,8	0,11067	3,1	0,13881	2,8
90,0	0,11961	2,8	0,11822	2,8	0,094952	3,0	0,12088	2,7
95,0	0,10435	2,7	0,10340	2,7	0,081780	3,0	0,10563	2,7
100,0	0,091314	2,6	0,090741	2,6	0,070690	2,9	0,092597	2,6
105,0	0,080265	2,6	0,079642	2,6	0,061383	2,8	0,081442	2,5
110,0	0,070764	2,5	0,070102	2,5	0,053486	2,7	0,071842	2,5
115,0	0,062544	2,4	0,061889	2,4	0,046730	2,7	0,063571	2,4
120,0	0,055431	2,4	0,054785	2,4	0,040955	2,6	0,056407	2,4
125,0	0,049252	2,3	0,048706	2,3	0,036006	2,5	0,050196	2,3
130,0	0,043872	2,3	0,043415	2,3	0,031747	2,5	0,044783	2,3
135,0	0,039254	2,2	0,038722	2,2	0,028097	2,4	0,040064	2,2

Standardized R/T Characteristics

Number	1006		1008		1009		1010	
T (°C)	$B_{25/100} = 3550$ K		$B_{25/100} = 3560$ K		$B_{25/100} = 3930$ K		$B_{25/100} = 3530$ K	
	R_T/R_{25}	α (%/K)	R_T/R_{25}	α (%/K)	R_T/R_{25}	α (%/K)	R_T/R_{25}	α (%/K)
140,0	0,035209	2,2	0,034615	2,2	0,024935	2,4	0,035928	2,2
145,0	0,031581	2,2	0,031048	2,1	0,022176	2,3	0,032302	2,1
150,0	0,028389	2,1	0,027910	2,1	0,019772	2,3	0,029107	2,1
155,0	0,025614	2,0	0,025193	2,0	0,017683	2,2	0,026291	2,0
160,0	0,023162	2,0	0,022790	2,0	0,015853	2,2	0,023801	2,0
165,0	0,020990	1,9	0,020667	2,0	0,014247	2,1	0,021594	1,9
170,0	0,019061	1,9	0,018780	1,9	0,012834	2,1	0,019634	1,9
175,0	0,017344	1,9	0,017090	1,9	0,011587	2,0	0,017888	1,8
180,0	0,015813	1,9	0,015582	1,8	0,010483	2,0	0,016331	1,8
185,0	–	–	0,014227	1,8	–	–	0,014931	1,8
190,0	–	–	0,013012	1,8	–	–	0,013681	1,7
195,0	–	–	0,011934	1,7	–	–	0,012558	1,7
200,0	–	–	0,010964	1,7	–	–	0,011547	1,7
205,0	–	–	0,010100	1,7	–	–	–	–
210,0	–	–	0,0093191	1,6	–	–	–	–
215,0	–	–	0,0085949	1,6	–	–	–	–
220,0	–	–	0,0079384	1,6	–	–	–	–
225,0	–	–	0,0073411	1,5	–	–	–	–
230,0	–	–	0,0067980	1,5	–	–	–	–
235,0	–	–	0,0063087	1,5	–	–	–	–
240,0	–	–	0,0058623	1,5	–	–	–	–
245,0	–	–	0,0054487	1,4	–	–	–	–
250,0	–	–	0,0050705	1,4	–	–	–	–

Standardized R/T Characteristics

Number	1011		1012		1013		1014	
T (°C)	$B_{25/100} = 3730$ K		$B_{25/100} = 4300$ K		$B_{25/100} = 3900$ K		$B_{25/100} = 4250$ K	
	R_T/R_{25}	α (%/K)	R_T/R_{25}	α (%/K)	R_T/R_{25}	α (%/K)	R_T/R_{25}	α (%/K)
-55,0	70,014	6,9	87,237	6,8	77,285	7,0	83,935	6,8
-50,0	49,906	6,7	62,264	6,7	54,938	6,7	60,228	6,6
-45,0	36,015	6,4	44,854	6,5	39,507	6,5	43,593	6,4
-40,0	26,296	6,2	32,599	6,3	28,722	6,3	31,815	6,3
-35,0	19,411	6,0	23,893	6,1	21,099	6,1	23,404	6,1
-30,0	14,479	5,8	17,654	6,0	15,652	5,9	17,349	6,0
-25,0	10,903	5,6	13,098	5,8	11,715	5,7	12,946	5,8
-20,0	8,2923	5,4	9,8059	5,7	8,8541	5,6	9,7439	5,7
-15,0	6,3591	5,2	7,4266	5,5	6,7433	5,4	7,3737	5,5
-10,0	4,9204	5,1	5,6677	5,4	5,1815	5,2	5,6247	5,4
- 5,0	3,8279	4,9	4,3213	5,3	4,0099	5,1	4,3063	5,3
0,0	3,0029	4,8	3,3208	5,1	3,1283	4,9	3,3221	5,2
5,0	2,3773	4,6	2,5842	5,0	2,4569	4,8	2,5779	5,0
10,0	1,8959	4,5	2,0238	4,9	1,9438	4,6	2,0144	4,9
15,0	1,5207	4,3	1,5858	4,8	1,5475	4,5	1,5848	4,8
20,0	1,2280	4,2	1,2507	4,7	1,2403	4,4	1,2547	4,6
25,0	1,0000	4,1	1,0000	4,5	1,0000	4,3	1,0000	4,6
30,0	0,81779	3,9	0,79640	4,4	0,81104	4,1	0,79913	4,4
35,0	0,67341	3,8	0,64053	4,3	0,66146	4,0	0,64287	4,3
40,0	0,55747	3,7	0,51772	4,2	0,54254	3,9	0,51991	4,2
45,0	0,46357	3,6	0,41958	4,1	0,44727	3,8	0,42299	4,1
50,0	0,38740	3,6	0,34172	4,1	0,37067	3,7	0,34573	4,1
55,0	0,32368	3,5	0,27877	4,0	0,30865	3,6	0,28298	4,0
60,0	0,27200	3,4	0,22861	3,9	0,25825	3,5	0,23277	3,8
65,0	0,23041	3,3	0,18872	3,8	0,21707	3,4	0,19262	3,8
70,0	0,19604	3,2	0,15645	3,7	0,18323	3,3	0,16005	3,7
75,0	0,16735	3,1	0,13012	3,6	0,15535	3,3	0,13349	3,6
80,0	0,14342	3,0	0,10863	3,6	0,13223	3,2	0,11175	3,5
85,0	0,12347	3,0	0,091115	3,5	0,11302	3,1	0,093934	3,5
90,0	0,10668	2,8	0,076700	3,4	0,096951	3,0	0,079231	3,4
95,0	0,092734	2,8	0,064867	3,3	0,083487	3,0	0,067054	3,3
100,0	0,080903	2,8	0,055047	3,3	0,072139	2,9	0,056932	3,2
105,0	0,070616	2,7	0,046797	3,2	0,062559	2,8	0,048591	3,1
110,0	0,061826	2,6	0,039904	3,1	0,054425	2,8	0,041605	3,1
115,0	0,054282	2,6	0,034255	3,1	0,047508	2,7	0,035653	3,1
120,0	0,047793	2,5	0,029498	3,0	0,041594	2,6	0,030636	3,0
125,0	0,042249	2,4	0,025448	3,0	0,036532	2,6	0,026454	2,9
130,0	0,037450	2,4	0,022016	2,9	0,032175	2,5	0,022905	2,9
135,0	0,033244	2,4	0,019038	2,8	0,028423	2,5	0,019867	2,8

Standardized R/T Characteristics

Number	1011		1012		1013		1014	
T (°C)	$B_{25/100} = 3730$ K		$B_{25/100} = 4300$ K		$B_{25/100} = 3900$ K		$B_{25/100} = 4250$ K	
	R_T/R_{25}	α (%/K)	R_T/R_{25}	α (%/K)	R_T/R_{25}	α (%/K)	R_T/R_{25}	α (%/K)
140,0	0,029582	2,3	0,016502	2,8	0,025173	2,4	0,017274	2,8
145,0	0,026406	2,3	0,014355	2,7	0,022358	2,4	0,015027	2,8
150,0	0,023625	2,2	0,012514	2,7	0,019907	2,3	0,013101	2,7
155,0	0,021193	2,1	0,010932	2,6	0,017770	2,2	0,011453	2,7
160,0	0,019057	2,1	0,0095681	2,6	0,015901	2,2	0,010031	2,6
165,0	0,017176	2,1	0,0083903	2,5	0,014263	2,2	0,0088012	2,6
170,0	0,015516	2,0	0,0073706	2,5	0,012824	2,1	0,0077359	2,6
175,0	0,014046	2,0	0,0065718	2,5	0,011556	2,1	0,0068109	2,5
180,0	0,012742	2,0	0,0058179	2,4	0,010436	2,1	0,0060061	2,5

Standardized R/T Characteristics

Number	1108		1101		1103		1106	
	$B_{25/100} = 3430 \text{ K}$		$B_{25/100} = 3430 \text{ K}$		$B_{25/100} = 4000 \text{ K}$		$B_{25/100} = 3950 \text{ K}$	
	R_T/R_{25}	α (%/K)	R_T/R_{25}	α (%/K)	R_T/R_{25}	α (%/K)	R_T/R_{25}	α (%/K)
-55,0	45,966	6,2	46,95	6,2	91,18	6,7	96,676	7,3
-50,0	33,988	5,9	34,75	6,0	65,09	6,6	67,117	7,1
-45,0	25,405	5,7	25,97	5,8	46,81	6,5	47,228	6,9
-40,0	19,182	5,5	19,58	5,6	33,91	6,4	33,656	6,7
-35,0	14,619	5,3	14,90	5,4	24,74	6,3	24,274	6,4
-30,0	11,240	5,2	11,43	5,2	18,18	6,1	17,706	6,2
-25,0	8,7149	5,0	8,845	5,1	13,46	6,0	13,050	6,0
-20,0	6,8103	4,9	6,897	4,9	10,06	5,8	9,7237	5,8
-15,0	5,3620	4,7	5,419	4,8	7,532	5,7	7,3106	5,6
-10,0	4,2519	4,6	4,288	4,6	5,694	5,5	5,5505	5,4
-5,0	3,3948	4,4	3,418	4,5	4,330	5,3	4,2360	5,3
0,0	2,7282	4,3	2,742	4,3	3,323	5,2	3,2629	5,1
5,0	2,2063	4,2	2,215	4,2	2,571	5,0	2,5337	4,9
10,0	1,7950	4,1	1,800	4,1	2,006	4,9	1,9841	4,8
15,0	1,4689	4,0	1,471	4,0	1,579	4,7	1,5680	4,6
20,0	1,2087	3,8	1,210	3,9	1,253	4,6	1,2484	4,5
25,0	1,0000	3,7	1,000	3,7	1,000	4,4	1,0000	4,4
30,0	0,83160	3,6	0,8312	3,6	0,8028	4,3	0,80641	4,2
35,0	0,69502	3,5	0,6944	3,5	0,6503	4,2	0,65453	4,1
40,0	0,58368	3,4	0,5831	3,4	0,5300	4,1	0,53457	4,0
45,0	0,49246	3,4	0,4919	3,4	0,4343	3,9	0,43942	3,9
50,0	0,41736	3,3	0,4168	3,3	0,3580	3,8	0,36320	3,8
55,0	0,35526	3,2	0,3548	3,2	0,2960	3,7	0,30154	3,7
60,0	0,30366	3,1	0,3033	3,1	0,2462	3,6	0,25166	3,6
65,0	0,26062	3,0	0,2604	3,0	0,2061	3,5	0,21119	3,5
70,0	0,22455	2,9	0,2244	2,9	0,1734	3,4	0,17808	3,4
75,0	0,19421	2,9	0,1941	2,9	0,1467	3,3	0,15079	3,3
80,0	0,16859	2,8	0,1685	2,8	0,1246	3,2	0,12824	3,2
85,0	0,14687	2,7	0,1468	2,7	0,1062	3,1	0,10940	3,1
90,0	0,12838	2,7	0,1283	2,7	0,09080	3,1	0,093690	3,0
95,0	0,11260	2,6	0,1126	2,6	0,07811	3,0	0,080675	3,0
100,0	0,099076	2,5	0,09906	2,5	0,06745	2,9	0,069728	2,9
105,0	0,087449	2,5	0,08744	2,5	0,05854	2,8	0,060405	2,8
110,0	0,077419	2,4	0,07741	2,4	0,05098	2,8	0,052497	2,8
115,0	0,068740	2,3	0,06873	2,4	0,04452	2,7	0,045765	2,7
120,0	0,061208	2,3	0,06119	2,3	0,03901	2,6	0,040013	2,6
125,0	0,054651	2,2	0,05462	2,2	0,03421	2,6	0,035083	2,6
130,0	0,048926	2,2	0,04889	2,2	0,03010	2,5	-	-
135,0	0,043914	2,1	0,04387	2,1	0,02664	2,4	-	-

Standardized R/T Characteristics

Number	1018		1101		1103		1106	
T (°C)	$B_{25/100} = 3430$ K		$B_{25/100} = 3430$ K		$B_{25/100} = 4000$ K		$B_{25/100} = 3950$ K	
	R_T/R_{25}	α (%/K)	R_T/R_{25}	α (%/K)	R_T/R_{25}	α (%/K)	R_T/R_{25}	α (%/K)
140,0	0,039515	2,1	0,03945	2,1	0,02364	2,4	—	—
145,0	0,035642	2,0	0,03557	2,1	0,02101	2,3	—	—
150,0	0,032225	2,0	0,03214	2,0	0,01872	2,3	—	—
155,0	0,029202	1,9	0,02911	2,0	0,01674	2,2	—	—
160,0	0,026521	1,9	0,02642	1,9	0,01501	2,2	—	—
165,0	0,024138	1,9	0,02403	1,9	0,01349	2,1	—	—
170,0	0,022016	1,8	0,02190	1,8	0,01216	2,1	—	—
175,0	0,020120	1,8	0,01999	1,8	0,01098	2,0	—	—
180,0	0,018424	1,7	0,01829	1,8	0,009935	2,0	—	—
185,0	0,016903	1,7	0,01676	1,7	—	—	—	—
190,0	0,015536	1,7	0,01539	1,7	—	—	—	—
195,0	0,014306	1,6	0,01415	1,7	—	—	—	—
200,0	0,013196	1,6	0,01304	1,6	—	—	—	—
205,0	0,012193	1,6	0,01203	1,6	—	—	—	—
210,0	0,011285	1,5	0,01112	1,6	—	—	—	—
215,0	0,010461	1,5	0,01029	1,5	—	—	—	—
220,0	0,0097128	1,5	0,009540	1,5	—	—	—	—
225,0	0,0090316	1,4	0,008856	1,5	—	—	—	—
230,0	0,0084106	1,4	0,008233	1,4	—	—	—	—
235,0	0,0078435	1,4	0,007665	1,4	—	—	—	—
240,0	0,0073249	1,4	0,007145	1,4	—	—	—	—
245,0	0,0068499	1,3	0,006669	1,4	—	—	—	—
250,0	0,0064141	1,3	0,006233	1,3	—	—	—	—

Standardized R/T Characteristics

Number	1201		1202		1203		1206	
	$B_{25/100} = 2600 \text{ K}$		$B_{25/100} = 2800 \text{ K}$		$B_{25/100} = 2900 \text{ K}$		$B_{25/100} = 2915 \text{ K}$	
	R_T/R_{25}	α (%/K)	R_T/R_{25}	α (%/K)	R_T/R_{25}	α (%/K)	R_T/R_{25}	α (%/K)
-55,0	21,445	5,1	27,119	5,5	30,252	5,6	30,21	5,6
-50,0	16,720	4,9	20,748	5,3	22,966	5,4	22,98	5,4
-45,0	13,159	4,7	16,035	5,1	17,612	5,2	17,65	5,2
-40,0	10,457	4,5	12,521	4,9	13,650	5,0	13,68	5,0
-35,0	8,3782	4,4	9,8633	4,7	10,671	4,8	10,70	4,8
-30,0	6,7701	4,2	7,8415	4,5	8,4216	4,7	8,439	4,7
-25,0	5,5112	4,0	6,2836	4,4	6,7001	4,5	6,713	4,5
-20,0	4,5207	3,9	5,0768	4,2	5,3757	4,3	5,383	4,3
-15,0	3,7332	3,8	4,1312	4,1	4,3443	4,2	4,349	4,2
-10,0	3,1041	3,6	3,3866	3,9	3,5376	4,1	3,540	4,1
-5,0	2,5966	3,5	2,7944	3,8	2,8995	3,9	2,901	3,9
0,0	2,1856	3,4	2,3211	3,7	2,3929	3,8	2,393	3,8
5,0	1,8498	3,3	1,9395	3,5	1,9866	3,7	1,987	3,7
10,0	1,5744	3,2	1,6303	3,4	1,6596	3,5	1,660	3,5
15,0	1,3469	3,1	1,3779	3,3	1,3941	3,4	1,394	3,4
20,0	1,1578	3,0	1,1709	3,2	1,1777	3,3	1,178	3,3
25,0	1,0000	2,9	1,0000	3,1	1,0000	3,2	1,000	3,2
30,0	0,86761	2,8	0,85816	3,0	0,85337	3,1	0,8534	3,1
35,0	0,75598	2,7	0,73986	2,9	0,73170	3,0	0,7317	3,0
40,0	0,66147	2,6	0,64074	2,8	0,63032	2,9	0,6302	2,9
45,0	0,58102	2,6	0,55721	2,8	0,54534	2,9	0,5452	2,9
50,0	0,51231	2,5	0,48657	2,7	0,47384	2,8	0,4735	2,8
55,0	0,45333	2,4	0,42652	2,6	0,41336	2,7	0,4130	2,7
60,0	0,40255	2,3	0,37530	2,5	0,36201	2,6	0,3615	2,6
65,0	0,35865	2,3	0,33141	2,5	0,31822	2,5	0,3176	2,6
70,0	0,32055	2,2	0,29364	2,4	0,28073	2,5	0,2800	2,5
75,0	0,28737	2,2	0,26105	2,3	0,24850	2,4	0,2476	2,4
80,0	0,25838	2,1	0,23280	2,3	0,22069	2,3	0,2197	2,4
85,0	0,23298	2,0	0,20826	2,2	0,19663	2,3	0,1955	2,3
90,0	0,21065	2,0	0,18683	2,1	0,17572	2,2	0,1745	2,2
95,0	0,19095	1,9	0,16809	2,1	0,15750	2,2	0,1562	2,2
100,0	0,17353	1,9	0,15164	2,0	0,14157	2,1	0,1402	2,1
105,0	0,15808	1,8	0,13715	2,0	0,12760	2,1	0,1262	2,1
110,0	0,14434	1,8	0,12436	1,9	0,11531	2,0	0,1138	2,0
115,0	0,13210	1,8	0,11304	1,9	0,10447	2,0	0,1029	2,0
120,0	0,12115	1,7	0,10299	1,8	0,094881	1,9	0,09328	1,9
125,0	0,11135	1,7	0,094040	1,8	0,086371	1,9	0,08473	1,9
130,0	0,10254	1,6	0,086055	1,8	0,078799	1,8	0,07713	1,9
135,0	0,094615	1,6	0,078918	1,7	0,072059	1,8	0,07035	1,8

Standardized R/T Characteristics

Number	1201		1202		1203		1206	
T (°C)	$B_{25/100} = 2600$ K		$B_{25/100} = 2800$ K		$B_{25/100} = 2900$ K		$B_{25/100} = 2915$ K	
	R_T/R_{25}	α (%/K)	R_T/R_{25}	α (%/K)	R_T/R_{25}	α (%/K)	R_T/R_{25}	α (%/K)
140,0	0,087464	1,6	0,072516	1,7	0,066032	1,7	0,06430	1,8
145,0	0,081103	1,5	0,066766	1,6	0,060629	1,7	0,05888	1,7
150,0	0,075148	1,5	0,061586	1,6	0,055776	1,6	0,05401	1,7
155,0	0,069838	1,5	0,056912	1,6	0,051415	1,6	0,04964	1,7
160,0	0,065007	1,4	0,052685	1,5	0,047481	1,6	0,04570	1,6
165,0	0,060607	1,4	0,048857	1,5	0,043927	1,5	0,04214	1,6
170,0	0,056590	1,4	0,045380	1,5	0,040708	1,5	0,03892	1,6
175,0	0,052920	1,3	0,042221	1,4	0,037792	1,5	0,03601	1,5
180,0	0,049557	1,3	0,039341	1,4	0,035140	1,5	0,03336	1,5

Standardized R/T Characteristics

Number	1207		1208		1209		1210	
	$B_{25/100} = 2965 \text{ K}$		$B_{25/100} = 3065 \text{ K}$		$B_{25/100} = 3165 \text{ K}$		$B_{25/100} = 3265 \text{ K}$	
	R_T/R_{25}	α (%/K)	R_T/R_{25}	α (%/K)	R_T/R_{25}	α (%/K)	R_T/R_{25}	α (%/K)
-55,0	31,68	5,7	34,65	5,8	37,65	5,9	41,62	6,0
-50,0	24,01	5,5	26,10	5,6	28,21	5,7	30,98	5,8
-45,0	18,37	5,3	19,85	5,4	21,34	5,5	23,28	5,6
-40,0	14,19	5,1	15,24	5,2	16,30	5,3	17,66	5,4
-35,0	11,06	4,9	11,81	5,0	12,56	5,1	13,52	5,3
-30,0	8,702	4,7	9,237	4,8	9,770	4,9	10,44	5,1
-25,0	6,901	4,6	7,283	4,7	7,662	4,8	8,137	4,9
-20,0	5,517	4,4	5,789	4,5	6,059	4,6	6,392	4,8
-15,0	4,445	4,3	4,637	4,4	4,828	4,5	5,061	4,6
-10,0	3,607	4,1	3,743	4,2	3,876	4,3	4,037	4,4
-5,0	2,948	4,0	3,042	4,1	3,134	4,2	3,244	4,3
0,0	2,426	3,8	2,489	4,0	2,552	4,1	2,625	4,2
5,0	2,008	3,7	2,050	3,8	2,091	3,9	2,138	4,0
10,0	1,673	3,6	1,699	3,7	1,724	3,8	1,753	3,9
15,0	1,402	3,5	1,416	3,6	1,430	3,7	1,446	3,8
20,0	1,181	3,4	1,187	3,5	1,193	3,6	1,199	3,7
25,0	1,0000	3,3	1,0000	3,4	1,0000	3,5	1,000	3,6
30,0	0,8511	3,2	0,8470	3,3	0,8429	3,4	0,8384	3,5
35,0	0,7279	3,1	0,7208	3,2	0,7139	3,3	0,7065	3,4
40,0	0,6254	3,0	0,6164	3,1	0,6076	3,2	0,5982	3,3
45,0	0,5396	2,9	0,5294	3,0	0,5194	3,1	0,5089	3,2
50,0	0,4676	2,8	0,4566	2,9	0,4459	3,0	0,4347	3,1
55,0	0,4068	2,8	0,3954	2,8	0,3844	2,9	0,3730	3,0
60,0	0,3553	2,7	0,3438	2,8	0,3327	2,9	0,3213	2,9
65,0	0,3114	2,6	0,3000	2,7	0,2890	2,8	0,2779	2,9
70,0	0,2739	2,5	0,2627	2,6	0,2520	2,7	0,2412	2,8
75,0	0,2417	2,5	0,2308	2,6	0,2205	2,6	0,2101	2,7
80,0	0,2140	2,4	0,2035	2,5	0,1935	2,6	0,1836	2,7
85,0	0,1900	2,3	0,1800	2,4	0,1704	2,5	0,1610	2,6
90,0	0,1693	2,3	0,1597	2,4	0,1505	2,5	0,1416	2,5
95,0	0,1512	2,2	0,1421	2,3	0,1334	2,4	0,1250	2,5
100,0	0,1354	2,2	0,1267	2,3	0,1185	2,3	0,1106	2,4
105,0	0,1216	2,1	0,1134	2,2	0,1056	2,3	0,09813	2,4
110,0	0,1095	2,1	0,1017	2,2	0,09431	2,2	0,08731	2,3
115,0	0,09882	2,0	0,09141	2,1	0,08446	2,2	0,07788	2,3
120,0	0,08940	2,0	0,08238	2,1	0,07582	2,1	0,06965	2,2
125,0	0,08106	1,9	0,07442	2,0	0,06823	2,1	0,06244	2,2
130,0	0,07365	1,9	0,06737	2,0	0,06153	2,0	0,05610	2,1
135,0	0,06706	1,9	0,06113	1,9	0,05562	2,0	0,05052	2,1

Standardized R/T Characteristics

Number	1207		1208		1209		1210	
T (°C)	$B_{25/100} = 2965$ K		$B_{25/100} = 3065$ K		$B_{25/100} = 3165$ K		$B_{25/100} = 3265$ K	
	R_T/R_{25}	α (%/K)	R_T/R_{25}	α (%/K)	R_T/R_{25}	α (%/K)	R_T/R_{25}	α (%/K)
140,0	0,06119	1,8	0,05557	1,9	0,05038	2,0	0,04560	2,0
145,0	0,05594	1,8	0,05063	1,8	0,04573	1,9	0,04124	2,0
150,0	0,05124	1,7	0,04621	1,8	0,04159	1,9	0,03737	2,0
155,0	0,04702	1,7	0,04226	1,8	0,03790	1,8	0,03393	1,9
160,0	0,04322	1,7	0,03871	1,7	0,03460	1,8	0,03087	1,9
165,0	0,03979	1,6	0,03553	1,7	0,03164	1,8	0,02814	1,8
170,0	0,03670	1,6	0,03266	1,7	0,02899	1,7	0,02569	1,8
175,0	0,03391	1,6	0,03007	1,6	0,02660	1,7	0,02349	1,8
180,0	0,03137	1,5	0,02773	1,6	0,02445	1,7	0,02152	1,7

Standardized R/T Characteristics

Number	1301		1302		1303		1304	
T (°C)	$B_{25/100} = 2600$ K		$B_{25/100} = 3000$ K		$B_{25/100} = 3050$ K		$B_{25/100} = 3300$ K	
	R_T/R_{25}	α (%/K)	R_T/R_{25}	α (%/K)	R_T/R_{25}	α (%/K)	R_T/R_{25}	α (%/K)
-55,0	21,45	5,1	33,701	5,9	34,363	5,8	39,326	5,5
-50,0	16,72	4,9	25,252	5,7	25,827	5,6	30,121	5,4
-45,0	13,16	4,7	19,149	5,4	19,635	5,4	23,164	5,3
-40,0	10,46	4,5	14,684	5,2	15,089	5,2	17,888	5,2
-35,0	8,378	4,3	11,380	5,0	11,712	5,0	13,874	5,1
-30,0	6,770	4,2	8,9067	4,8	9,1774	4,8	10,810	5,0
-25,0	5,511	4,0	7,0357	4,6	7,2552	4,6	8,4512	4,9
-20,0	4,521	3,9	5,6065	4,5	5,7835	4,5	6,6612	4,8
-15,0	3,733	3,8	4,5044	4,3	4,6467	4,3	5,2540	4,7
-10,0	3,104	3,6	3,6471	4,2	3,7611	4,2	4,1777	4,6
-5,0	2,597	3,5	2,9746	4,0	3,0547	4,1	3,3309	4,5
0,0	2,186	3,4	2,4429	3,9	2,4986	4,0	2,6767	4,3
5,0	1,850	3,3	2,0194	3,8	2,0575	3,8	2,1680	4,1
10,0	1,574	3,2	1,6797	3,6	1,7051	3,7	1,7683	4,0
15,0	1,347	3,1	1,4053	3,5	1,4210	3,6	1,4538	3,9
20,0	1,158	3,0	1,1823	3,4	1,1910	3,6	1,2025	3,8
25,0	1,000	2,9	1,0000	3,3	1,0000	3,3	1,0000	3,6
30,0	0,8676	2,8	0,85007	3,2	0,85053	3,3	0,83752	3,5
35,0	0,7560	2,7	0,72608	3,1	0,72386	3,2	0,70362	3,4
40,0	0,6615	2,6	0,62300	3,0	0,61897	3,1	0,59417	3,3
45,0	0,5810	2,6	0,53685	2,9	0,53134	3,0	0,50453	3,2
50,0	0,5123	2,5	0,46453	2,9	0,45814	2,9	0,43035	3,2
55,0	0,4533	2,4	0,40357	2,8	0,39637	2,9	0,36798	3,1
60,0	0,4025	2,3	0,35193	2,7	0,34439	2,7	0,31608	3,0
65,0	0,3587	2,3	0,30799	2,6	0,30081	2,7	0,27324	2,9
70,0	0,3206	2,2	0,27047	2,6	0,26372	2,6	0,23718	2,8
75,0	0,2874	2,2	0,23832	2,5	0,23212	2,5	0,20635	2,7
80,0	0,2584	2,1	0,21067	2,4	0,20501	2,5	0,18016	2,7
85,0	0,2330	2,0	0,18677	2,4	0,18150	2,4	0,15843	2,6
90,0	0,2107	2,0	0,16607	2,3	0,16117	2,4	0,13984	2,5
95,0	0,1910	1,9	0,14805	2,3	0,14330	2,3	0,12277	2,5
100,0	0,1735	1,9	0,13233	2,2	0,12775	2,2	0,10804	2,4
105,0	0,1581	1,8	0,11862	2,2	0,11458	2,1	0,095996	2,3
110,0	0,1443	1,8	0,10660	2,1	0,10306	2,1	0,085543	2,3
115,0	0,1321	1,8	0,096009	2,1	0,092752	2,1	0,076380	2,2
120,0	0,1212	1,7	0,086667	2,0	0,083677	2,0	0,068378	2,2
125,0	0,1114	1,7	0,078398	2,0	0,075739	2,0	0,061386	2,1
130,0	0,1025	1,6	0,071067	1,9	0,068710	1,9	0,055245	2,1
135,0	0,09462	1,6	0,064544	1,9	0,062431	1,9	0,049926	2,0

Standardized R/T Characteristics

Number	1301		1302		1303		1304	
T (°C)	$B_{25/100} = 2600$ K		$B_{25/100} = 3000$ K		$B_{25/100} = 3050$ K		$B_{25/100} = 3300$ K	
	R_T/R_{25}	α (%/K)	R_T/R_{25}	α (%/K)	R_T/R_{25}	α (%/K)	R_T/R_{25}	α (%/K)
140,0	0,08746	1,6	0,058733	1,9	0,056844	1,9	0,045227	2,0
145,0	0,08100	1,5	0,053561	1,8	0,051849	1,8	0,041008	1,9
150,0	0,07515	1,5	0,048933	1,8	0,047384	1,8	0,037262	1,9
155,0	0,06984	1,4	0,044793	1,8	0,043383	1,8	0,033961	1,8
160,0	0,06501	1,4	0,041077	1,7	0,039788	1,7	0,031019	1,8
165,0	0,06061	1,4	0,037736	1,7	0,036552	1,7	0,028389	1,8
170,0	0,05659	1,4	0,034726	1,6	0,033632	1,7	0,026034	1,7
175,0	0,05292	1,3	0,032009	1,6	0,030993	1,6	0,023920	1,7
180,0	0,04956	1,3	0,029553	1,6	0,028604	1,6	0,022018	1,7

Standardized R/T Characteristics

Number	1305		1306		1307		1308	
T (°C)	$B_{25/100} = 3200$ K		$B_{25/100} = 3450$ K		$B_{25/100} = 3560$ K		$B_{25/100} = 3060$ K	
	R_T/R_{25}	α (%/K)	R_T/R_{25}	α (%/K)	R_T/R_{25}	α (%/K)	R_T/R_{25}	α (%/K)
-55,0	42,131	6,2	49,935	6,3	51,115	5,9	32,33	5,6
-50,0	31,129	5,9	36,640	6,1	38,300	5,8	24,58	5,4
-45,0	23,273	5,7	27,180	5,9	28,847	5,7	18,85	5,2
-40,0	17,592	5,5	20,370	5,7	21,842	5,6	14,58	5,0
-35,0	13,438	5,3	15,416	5,5	16,627	5,5	11,38	4,9
-30,0	10,366	5,0	11,775	5,3	12,725	5,4	8,947	4,7
-25,0	8,1005	4,9	9,0698	5,1	9,7859	5,2	7,091	4,6
-20,0	6,3856	4,8	7,0497	5,0	7,5902	5,2	5,663	4,4
-15,0	5,0364	4,7	5,5187	4,8	5,8918	5,0	4,555	4,3
-10,0	4,0067	4,4	4,3558	4,7	4,6124	4,9	3,689	4,1
- 5,0	3,2217	4,3	3,4609	4,5	3,6247	4,7	3,008	4,0
0,0	2,6097	4,2	2,7705	4,4	2,8717	4,6	2,468	3,9
5,0	2,1260	4,0	2,2313	4,3	2,2929	4,4	2,037	3,8
10,0	1,7438	3,9	1,8098	4,1	1,8442	4,3	1,691	3,7
15,0	1,4415	3,8	1,4762	4,0	1,4941	4,2	1,412	3,6
20,0	1,1987	3,7	1,2116	3,9	1,2183	4,0	1,185	3,5
25,0	1,0000	3,5	1,0000	3,8	1,0000	4,0	1,000	3,4
30,0	0,84185	3,4	0,82984	3,7	0,82246	3,8	0,8478	3,3
35,0	0,71080	3,3	0,69220	3,6	0,68231	3,7	0,7221	3,2
40,0	0,60317	3,2	0,58042	3,5	0,56909	3,6	0,6179	3,1
45,0	0,51419	3,1	0,48899	3,4	0,47670	3,5	0,5309	3,0
50,0	0,44037	3,1	0,41395	3,3	0,40133	3,4	0,4581	2,9
55,0	0,37824	3,0	0,35197	3,2	0,33894	3,3	0,3968	2,8
60,0	0,32636	2,9	0,30060	3,1	0,28769	3,2	0,3450	2,8
65,0	0,28333	2,8	0,25780	3,0	0,24573	3,1	0,3011	2,7
70,0	0,24697	2,7	0,22197	3,0	0,21081	3,0	0,2637	2,6
75,0	0,21573	2,7	0,19189	2,9	0,18147	3,0	0,2317	2,6
80,0	0,18908	2,6	0,16648	2,8	0,15682	2,9	0,2042	2,5
85,0	0,16649	2,5	0,14498	2,7	0,13601	2,8	0,1806	2,4
90,0	0,14709	2,5	0,12669	2,7	0,11838	2,7	0,1602	2,4
95,0	0,13021	2,4	0,11109	2,6	0,10342	2,7	0,1425	2,3
100,0	0,11560	2,3	0,097717	2,5	0,090649	2,6	0,1271	2,3
105,0	0,10301	2,3	0,086235	2,5	0,079672	2,6	0,1136	2,2
110,0	0,092038	2,2	0,076325	2,4	0,070236	2,5	0,1019	2,2
115,0	0,082442	2,2	0,067760	2,4	0,062118	2,4	0,09158	2,1
120,0	0,074035	2,1	0,060320	2,3	0,055093	2,4	0,08251	2,1
125,0	0,066701	2,1	0,053852	2,2	0,048901	2,4	0,07451	2,0
130,0	0,060238	2,0	0,048200	2,2	0,043513	2,3	0,06744	2,0
135,0	0,054515	2,0	0,043256	2,1	0,038925	2,2	0,06117	1,9

Standardized R/T Characteristics

Number	1305		1306		1307		1308	
T (°C)	$B_{25/100} = 3200$ K		$B_{25/100} = 3450$ K		$B_{25/100} = 3560$ K		$B_{25/100} = 3060$ K	
	R_T/R_{25}	α (%/K)	R_T/R_{25}	α (%/K)	R_T/R_{25}	α (%/K)	R_T/R_{25}	α (%/K)
140,0	0,049446	1,9	0,038911	2,1	0,034908	2,2	0,05559	1,9
145,0	0,044944	1,9	0,035091	2,0	0,031349	2,1	0,05063	1,9
150,0	0,040937	1,8	0,031716	2,0	0,028216	2,1	0,04620	1,8
155,0	0,037362	1,8	0,028733	2,0	0,025477	2,0	0,04224	1,8
160,0	0,034165	1,8	0,026088	1,9	0,023056	2,0	0,03869	1,7
165,0	0,031300	1,7	0,023738	1,8	0,020911	1,9	0,03550	1,7
170,0	0,028726	1,7	0,021644	1,8	0,019006	1,9	0,03263	1,7
175,0	0,026410	1,7	0,019775	1,6	0,017309	1,9	0,03003	1,6
180,0	0,024322	1,7	0,018104	1,6	0,015796	1,9	0,02770	1,6

Standardized R/T Characteristics

Number	1309		2001		2002		2003	
T (°C)	$B_{25/100} = 3520$ K		$B_{25/100} = 3920$ K		$B_{25/100} = 3940$ K		$B_{25/100} = 3980$ K	
	R_T/R_{25}	α (%/K)	R_T/R_{25}	α (%/K)	R_T/R_{25}	α (%/K)	R_T/R_{25}	α (%/K)
-55,0	48,460	6,1	87,762	7,1	88,463	7,2	97,578	7,5
-50,0	35,800	6,0	61,922	6,9	62,368	6,9	67,650	7,2
-45,0	26,694	5,8	44,168	6,7	44,461	6,7	47,538	7,0
-40,0	20,085	5,6	31,833	6,5	32,032	6,5	33,831	6,7
-35,0	15,247	5,4	23,173	6,3	23,312	6,3	24,359	6,5
-30,0	11,674	5,3	17,030	6,1	17,130	6,1	17,753	6,3
-25,0	9,0124	5,1	12,621	5,9	12,695	5,9	13,067	6,0
-20,0	7,0136	4,9	9,4515	5,8	9,5068	5,8	9,7228	5,8
-15,0	5,5001	4,8	7,1273	5,6	7,1700	5,6	7,3006	5,6
-10,0	4,3451	4,6	5,4270	5,5	5,4595	5,5	5,5361	5,5
- 5,0	3,4569	4,5	4,1522	5,3	4,1779	5,3	4,2332	5,3
0,0	2,7688	4,4	3,2063	5,1	3,2263	5,1	3,2660	5,1
5,0	2,2321	4,2	2,5019	4,9	2,5112	4,9	2,5392	5,0
10,0	1,8105	4,1	1,9679	4,7	1,9707	4,7	1,9902	4,8
15,0	1,4773	4,0	1,5623	4,6	1,5618	4,6	1,5709	4,7
20,0	1,2122	3,9	1,2488	4,5	1,2465	4,5	1,2492	4,5
25,0	1,0000	3,8	1,0000	4,3	1,0000	4,3	1,0000	4,4
30,0	0,82924	3,7	0,81105	4,2	0,80868	4,2	0,80575	4,3
35,0	0,69105	3,6	0,65930	4,1	0,65735	4,1	0,65326	4,1
40,0	0,57861	3,5	0,53922	4,0	0,53754	4,0	0,53290	4,0
45,0	0,48666	3,4	0,44345	3,9	0,44242	3,8	0,43715	3,9
50,0	0,41110	3,3	0,36674	3,7	0,36605	3,8	0,36064	3,8
55,0	0,34872	3,3	0,30513	3,6	0,30398	3,7	0,29908	3,7
60,0	0,29699	3,2	0,25514	3,5	0,25373	3,5	0,24932	3,6
65,0	0,25390	3,1	0,21457	3,4	0,21310	3,4	0,20886	3,5
70,0	0,21786	3,0	0,18131	3,4	0,17982	3,4	0,17578	3,4
75,0	0,18759	3,0	0,15360	3,3	0,15227	3,3	0,14863	3,3
80,0	0,16208	2,9	0,13064	3,2	0,12948	3,2	0,12621	3,2
85,0	0,14050	2,8	0,11155	3,1	0,11034	3,2	0,10763	3,1
90,0	0,12217	2,8	0,095606	3,0	0,094357	3,0	0,092159	3,1
95,0	0,10656	2,7	0,082347	3,0	0,081215	3,0	0,079225	3,0
100,0	0,093213	2,6	0,071180	2,9	0,070155	2,9	0,068356	2,9
105,0	0,081767	2,6	0,061779	2,8	0,060801	2,8	0,059247	2,8
110,0	0,071922	2,5	0,053799	2,8	0,052869	2,8	0,051531	2,8
115,0	0,063428	2,5	0,046970	2,7	0,046109	2,7	0,044921	2,7
120,0	0,056078	2,4	0,041132	2,6	0,040336	2,6	0,039282	2,7
125,0	0,049702	2,4	0,036141	2,6	0,035408	2,6	0,034387	2,6
130,0	0,044155	2,3	0,031847	2,5	0,031170	2,5	0,030186	2,5
135,0	0,039316	2,3	0,028153	2,4	0,027502	2,5	0,026650	2,5

Standardized R/T Characteristics

Number	1309		2001		2002		2003	
T (°C)	$B_{25/100} = 3520$ K		$B_{25/100} = 3920$ K		$B_{25/100} = 3940$ K		$B_{25/100} = 3980$ K	
	R_T/R_{25}	α (%/K)	R_T/R_{25}	α (%/K)	R_T/R_{25}	α (%/K)	R_T/R_{25}	α (%/K)
140,0	0,035086	2,3	0,024955	2,4	0,024329	2,4	0,023594	2,4
145,0	0,031377	2,2	0,022158	2,4	0,021563	2,4	0,020931	2,4
150,0	0,028119	2,2	0,019722	2,3	0,019157	2,3	0,018616	2,3
155,0	0,025250	2,1	0,017607	2,2	0,017074	2,3	0,016612	2,3
160,0	0,022717	2,1	0,015756	2,2	0,015253	2,2	0,014861	2,2
165,0	0,020478	2,1	0,014132	2,2	0,013654	2,2	0,013327	2,2
170,0	0,018493	2,0	0,012703	2,1	0,012248	2,1	0,011980	2,1
175,0	0,016731	2,0	0,011444	2,1	0,011016	2,1	0,010794	2,1
180,0	0,015162	2,0	0,010331	2,1	0,009927	2,1	0,0097471	2,1

Standardized R/T Characteristics

Number	2004		2005		2006		2007	
T (°C)	$B_{25/100} = 4100$ K		$B_{25/100} = 4600$ K		$B_{25/100} = 5000$ K		$B_{25/100} = 4830$ K	
	R_T/R_{25}	α (%/K)	R_T/R_{25}	α (%/K)	R_T/R_{25}	α (%/K)	R_T/R_{25}	α (%/K)
-55,0	99,552	7,6	120,22	7,0	200,55	8,7	185,87	8,4
-50,0	68,582	7,3	85,480	6,9	131,02	8,3	123,23	8,1
-45,0	47,963	7,0	61,004	6,8	87,171	8,0	82,888	7,8
-40,0	34,019	6,7	43,712	6,7	58,988	7,7	56,544	7,6
-35,0	24,448	6,5	31,459	6,6	40,545	7,4	39,061	7,3
-30,0	17,787	6,3	22,746	6,6	28,272	7,1	27,321	7,1
-25,0	13,083	6,1	16,490	6,4	19,997	6,9	19,326	6,8
-20,0	9,7251	5,8	12,071	6,3	14,292	6,6	13,823	6,6
-15,0	7,3160	5,6	8,8455	6,1	10,350	6,4	10,001	6,4
-10,0	5,5545	5,4	6,5446	6,0	7,5614	6,4	7,3067	6,4
-5,0	4,2531	5,3	4,8852	5,8	5,5343	6,2	5,3454	6,2
0,0	3,2836	5,1	3,6781	5,6	4,0860	6,0	3,9484	5,9
5,0	2,5512	5,0	2,7944	5,4	3,0374	5,9	2,9595	5,7
10,0	1,9973	4,8	2,1391	5,3	2,2760	5,7	2,2358	5,6
15,0	1,5738	4,7	1,6507	5,1	1,7188	5,6	1,7001	5,4
20,0	1,2488	4,5	1,2823	5,1	1,3074	5,5	1,3021	5,4
25,0	1,0000	4,5	1,0000	5,0	1,0000	5,3	1,0000	5,2
30,0	0,80080	4,3	0,78393	4,8	0,76988	5,2	0,77560	5,0
35,0	0,64733	4,2	0,61822	4,7	0,59540	5,1	0,60507	4,9
40,0	0,52628	4,0	0,49053	4,6	0,46341	4,9	0,47498	4,8
45,0	0,43263	3,9	0,39116	4,5	0,36327	4,8	0,37533	4,7
50,0	0,35708	3,9	0,31371	4,3	0,28636	4,8	0,29823	4,6
55,0	0,29406	3,8	0,25338	4,2	0,22620	4,7	0,23763	4,5
60,0	0,24342	3,7	0,20565	4,2	0,17974	4,5	0,19041	4,4
65,0	0,20278	3,6	0,16762	4,1	0,14380	4,4	0,15356	4,3
70,0	0,16964	3,5	0,13726	4,0	0,11560	4,3	0,12442	4,2
75,0	0,14257	3,4	0,11279	3,9	0,093296	4,3	0,10131	4,1
80,0	0,12028	3,4	0,093053	3,8	0,075623	4,2	0,082860	4,0
85,0	0,10196	3,3	0,077177	3,7	0,061619	4,1	0,068004	3,9
90,0	0,086757	3,3	0,064263	3,6	0,050414	3,9	0,056032	3,8
95,0	0,073804	3,2	0,053678	3,6	0,041532	3,8	0,046379	3,8
100,0	0,062974	3,0	0,044996	3,5	0,034355	3,8	0,038533	3,7
105,0	0,054276	2,9	0,037917	3,4	0,028525	3,7	0,032169	3,6
110,0	0,046943	3,0	0,032063	3,4	0,023774	3,7	0,026952	3,5
115,0	0,040576	2,9	0,027161	3,3	0,019852	3,6	0,022658	3,4
120,0	0,035174	2,8	0,023079	3,2	0,016632	3,5	0,019111	3,3
125,0	0,030637	2,7	0,019680	3,2	0,014016	3,4	0,016201	3,3
130,0	0,026760	2,7	0,016831	3,1	0,011850	3,4	0,013778	3,2
135,0	0,023425	2,6	0,014457	3,0	0,010043	3,3	0,011742	3,2

Standardized R/T Characteristics

Number	2004		2005		2006		2007	
T (°C)	$B_{25/100} = 4100$ K		$B_{25/100} = 4600$ K		$B_{25/100} = 5000$ K		$B_{25/100} = 4830$ K	
	R_T/R_{25}	α (%/K)	R_T/R_{25}	α (%/K)	R_T/R_{25}	α (%/K)	R_T/R_{25}	α (%/K)
140,0	0,020559	2,6	0,012453	3,0	0,0085371	3,2	0,010035	3,2
145,0	0,018097	2,5	0,010756	2,9	0,0072791	3,2	0,0085864	3,1
150,0	0,015969	2,5	0,0093154	2,8	0,0062238	3,1	0,0073657	3,1
155,0	0,014129	2,4	0,0080948	2,8	0,0053381	3,0	0,0067293	3,2
160,0	0,012534	2,4	0,0070537	2,7	0,0045915	3,0	0,0054517	2,9
165,0	0,011146	2,3	0,0061631	2,7	0,0039601	2,9	0,0047230	2,9
170,0	0,0099357	2,3	0,0053990	2,6	0,0034248	2,9	0,0041014	2,8
175,0	0,0088782	2,2	0,0047417	2,6	0,0029696	2,8	0,0035715	2,8
180,0	0,0079517	2,2	0,0041746	2,6	0,0025814	2,8	0,0031171	2,8

Standardized R/T Characteristics

Number	2101		2901		2903		2904	
T (°C)	$B_{25/100} = 4100$ K		$B_{25/100} = 3760$ K		$B_{25/100} = 4200$ K		$B_{25/100} = 4300$ K	
	R_T/R_{25}	α (%/K)	R_T/R_{25}	α (%/K)	R_T/R_{25}	α (%/K)	R_T/R_{25}	α (%/K)
-55,0	104,09	7,5	63,969	6,7	120,03	7,7	121,46	7,4
-50,0	72,101	7,2	46,179	6,4	82,380	7,4	84,439	7,2
-45,0	50,572	7,0	33,738	6,2	57,248	7,2	59,243	7,1
-40,0	35,898	6,7	24,927	6,0	40,255	7,0	41,938	6,9
-35,0	25,774	6,5	18,611	5,8	28,627	6,7	29,947	6,7
-30,0	18,707	6,3	14,033	5,6	20,577	6,6	21,567	6,6
-25,0	13,720	6,1	10,679	5,4	14,876	6,4	15,641	6,3
-20,0	10,163	5,9	8,1980	5,3	10,880	6,1	11,466	6,2
-15,0	7,5998	5,7	6,3123	5,2	8,0808	5,9	8,4510	6,0
-10,0	5,7351	5,5	4,9014	5,1	6,0612	5,8	6,2927	5,9
-5,0	4,3657	5,4	3,8210	4,9	4,5649	5,6	4,7077	5,7
0,0	3,3511	5,2	3,0027	4,7	3,4708	5,4	3,5563	5,5
5,0	2,5929	5,1	2,3801	4,6	2,6625	5,2	2,7119	5,3
10,0	2,0216	4,9	1,9000	4,5	2,0599	5,1	2,0860	5,1
15,0	1,5878	4,8	1,5257	4,3	1,6069	4,9	1,6204	5,0
20,0	1,2558	4,6	1,2330	4,3	1,2631	4,8	1,2683	4,8
25,0	1,0000	4,5	1,0000	4,1	1,0000	4,6	1,0000	4,7
30,0	0,80145	4,4	0,81679	4,0	0,79593	4,5	0,79420	4,6
35,0	0,64632	4,2	0,67166	3,9	0,63796	4,4	0,63268	4,5
40,0	0,52433	4,1	0,55527	3,8	0,51467	4,2	0,50740	4,3
45,0	0,42781	4,0	0,46095	3,8	0,41887	4,1	0,41026	4,2
50,0	0,35099	3,9	0,38459	3,7	0,34272	4,0	0,33363	4,1
55,0	0,28949	3,8	0,32184	3,6	0,28081	3,9	0,27243	4,0
60,0	0,23998	3,7	0,27068	3,5	0,23141	3,8	0,22370	3,9
65,0	0,19992	3,6	0,22907	3,3	0,19211	3,7	0,18459	3,8
70,0	0,16733	3,5	0,19468	3,2	0,16027	3,6	0,15305	3,7
75,0	0,14070	3,4	0,16607	3,1	0,13421	3,5	0,12755	3,6
80,0	0,11882	3,3	0,14221	3,1	0,11288	3,4	0,10677	3,5
85,0	0,10077	3,3	0,12218	3,0	0,095326	3,3	0,089928	3,4
90,0	0,085806	3,2	0,10533	2,9	0,080828	3,2	0,076068	3,3
95,0	0,073354	3,1	0,09123	2,8	0,068916	3,2	0,064524	3,3
100,0	0,062947	3,0	0,079284	2,8	0,058989	3,1	0,054941	3,2
105,0	0,054214	3,0	0,069062	2,7	0,050701	3,0	0,047003	3,1
110,0	0,046858	2,9	0,060340	2,7	0,043735	3,0	0,040358	3,0
115,0	0,040638	2,8	0,052886	2,6	0,037778	2,9	0,034743	3,0
120,0	0,035361	2,8	0,046482	2,5	0,032736	2,8	0,030007	2,9
125,0	0,030866	2,7	0,040985	2,5	0,028513	2,7	0,026006	2,8
130,0	0,027027	2,6	0,036233	2,5	0,024912	2,7	0,022609	2,8
135,0	0,023735	2,6	0,032101	2,4	0,021804	2,6	0,019720	2,7

Standardized R/T Characteristics

Number	2101		2901		2903		2904	
T (°C)	$B_{25/100} = 4100$ K		$B_{25/100} = 3760$ K		$B_{25/100} = 4200$ K		$B_{25/100} = 4300$ K	
	R_T/R_{25}	α (%/K)	R_T/R_{25}	α (%/K)	R_T/R_{25}	α (%/K)	R_T/R_{25}	α (%/K)
140,0	0,020904	2,5	0,028510	2,4	0,019136	2,6	0,017251	2,6
145,0	0,018463	2,5	0,025373	2,3	0,016848	2,5	0,015139	2,6
150,0	0,016351	2,4	0,022633	2,3	0,014872	2,5	0,013321	2,5
155,0	0,014518	2,4	0,020231	2,3	0,013165	2,4	0,011754	2,5
160,0	0,012923	2,3	0,018121	2,2	0,011686	2,4	0,010399	2,4
165,0	0,011532	2,3	0,016262	2,2	0,010400	2,3	0,0092238	2,4
170,0	0,010315	2,2	0,014621	2,1	0,0092790	2,3	0,0082017	2,3
175,0	0,0092480	2,2	0,013170	2,1	0,0082997	2,2	0,0073104	2,3
180,0	0,0083098	2,1	0,011883	2,1	0,0074419	2,2	0,0065312	2,3

Standardized R/T Characteristics

Number	2910		3202		3204		3205	
	$B_{25/100} = 3950 \text{ K}$		$B_{25/100} = 3975 \text{ K}$		$B_{25/100} = 3250 \text{ K}$		$B_{25/100} = 3300 \text{ K}$	
	R_T/R_{25}	α (%/K)	R_T/R_{25}	α (%/K)	R_T/R_{25}	α (%/K)	R_T/R_{25}	α (%/K)
-55,0	82,040	7,1	81,252	7,0	42,253	5,7	48,569	6,4
-50,0	58,010	6,8	57,704	6,8	31,775	5,7	35,504	6,2
-45,0	41,510	6,6	41,437	6,6	23,937	5,6	26,252	5,9
-40,0	30,040	6,4	30,070	6,3	18,124	5,5	19,625	5,7
-35,0	21,970	6,2	22,039	6,2	13,821	5,3	14,827	5,5
-30,0	16,230	6,0	16,307	6,0	10,627	5,2	11,315	5,3
-25,0	12,100	5,8	12,170	5,8	8,2453	5,0	8,7191	5,1
-20,0	9,1080	5,6	9,1710	5,6	6,4556	4,8	6,7805	4,9
-15,0	6,9140	5,4	6,9604	5,4	5,0997	4,6	5,3194	4,8
-10,0	5,2930	5,3	5,3296	5,3	4,0631	4,5	4,2082	4,6
-5,0	4,0840	5,1	4,1086	5,1	3,2632	4,3	3,3557	4,5
0,0	3,1750	5,0	3,1930	5,0	2,6403	4,2	2,6963	4,3
5,0	2,4860	4,8	2,4974	4,9	2,1508	4,0	2,1822	4,2
10,0	1,9610	4,7	1,9680	4,7	1,7627	3,9	1,7784	4,0
15,0	1,5570	4,6	1,5602	4,6	1,4525	3,8	1,4588	3,9
20,0	1,2440	4,4	1,2454	4,5	1,2027	3,7	1,2042	3,8
25,0	1,0000	4,3	1,0000	4,3	1,0000	3,5	1,0000	3,7
30,0	0,80880	4,2	0,80774	4,2	0,84385	3,4	0,83517	3,6
35,0	0,65800	4,1	0,65610	4,1	0,71266	3,4	0,70132	3,4
40,0	0,53820	4,0	0,53604	4,0	0,60319	3,3	0,59200	3,3
45,0	0,44260	3,9	0,44020	3,9	0,51216	3,2	0,50221	3,2
50,0	0,36580	3,8	0,36345	3,8	0,43654	3,2	0,42807	3,2
55,0	0,30400	3,7	0,30153	3,7	0,37367	3,1	0,36654	3,1
60,0	0,25370	3,6	0,25140	3,6	0,32128	3,0	0,31522	3,0
65,0	0,21280	3,5	0,21059	3,5	0,27750	2,9	0,27222	2,9
70,0	0,17920	3,4	0,17718	3,4	0,24078	2,8	0,23603	2,8
75,0	0,15160	3,3	0,14975	3,3	0,20985	2,7	0,20543	2,7
80,0	0,12880	3,2	0,12708	3,2	0,18368	2,6	0,17946	2,7
85,0	0,10990	3,1	0,10830	3,2	0,16142	2,5	0,15733	2,6
90,0	0,094060	3,1	0,092645	3,1	0,14239	2,5	0,13839	2,5
95,0	0,080840	3,0	0,079573	3,0	0,12606	2,4	0,12213	2,5
100,0	0,069740	2,9	0,068586	2,9	0,11196	2,3	0,10811	2,4
105,0	0,060360	2,9	0,059338	2,9	0,099734	2,3	0,095998	2,4
110,0	0,052430	2,8	0,051506	2,8	0,089081	2,2	0,085486	2,3
115,0	0,045690	2,7	0,044869	2,7	0,079757	2,2	0,076337	2,2
120,0	0,039940	2,7	0,039207	2,7	0,071561	2,1	0,068350	2,2
125,0	0,035030	2,6	0,034374	2,6	0,064327	2,1	0,061358	2,1
130,0	0,030810	2,5	0,030224	2,5	0,057918	2,1	0,055218	2,1
135,0	0,027180	2,5	0,026658	2,5	0,052219	2,1	0,049812	2,0

Standardized R/T Characteristics

Number	2910		3202		3204		3205	
T (°C)	$B_{25/100} = 3950$ K		$B_{25/100} = 3975$ K		$B_{25/100} = 3250$ K		$B_{25/100} = 3300$ K	
	R_T/R_{25}	α (%/K)	R_T/R_{25}	α (%/K)	R_T/R_{25}	α (%/K)	R_T/R_{25}	α (%/K)
140,0	0,024040	2,4	0,023577	2,4	0,047136	2,0	0,045039	2,0
145,0	0,021320	2,4	0,020912	2,4	0,042587	2,0	0,040815	2,0
150,0	0,018960	2,3	0,018595	2,3	0,038506	2,0	0,037067	1,9
155,0	0,016910	2,3	0,016581	2,3	0,034837	2,0	0,033733	1,9
160,0	0,015110	2,2	0,014823	2,2	0,031529	2,0	0,030762	1,8
165,0	0,013540	2,2	0,013285	2,2	0,028543	2,0	0,028107	1,8
170,0	0,012160	2,1	0,011935	2,1	0,025843	1,9	0,025729	1,8
175,0	0,010940	2,1	0,010749	2,1	0,023397	1,9	0,023596	1,7
180,0	0,009873	2,0	0,0097026	2,1	0,021180	1,9	0,021678	1,7
185,0	0,008925	2,0	–	–	–	–	–	–
190	0,008085	2,0	–	–	–	–	–	–
195	0,007339	1,9	–	–	–	–	–	–
200	0,006675	1,9	–	–	–	–	–	–

Standardized R/T Characteristics

Number	3206		3207		4001		4002	
T (°C)	$B_{25/100} = 3450$ K		$B_{25/100} = 3100$ K		$B_{25/100} = 3950$ K		$B_{25/100} = 4250$ K	
	R_T/R_{25}	α (%/K)	R_T/R_{25}	α (%/K)	R_T/R_{25}	α (%/K)	R_T/R_{25}	α (%/K)
-55,0	59,147	6,7	36,781	5,9	88,052	7,3	113,41	7,7
-50,0	42,651	6,4	27,559	5,7	61,650	7,0	77,695	7,4
-45,0	31,088	6,2	20,858	5,5	43,727	6,8	54,008	7,1
-40,0	22,903	6,0	15,942	5,3	31,395	6,5	38,056	6,9
-35,0	17,052	5,8	12,299	5,1	22,802	6,3	27,159	6,6
-30,0	12,827	5,6	9,5753	4,9	16,742	6,2	19,615	6,4
-25,0	9,7461	5,4	7,5194	4,8	12,367	6,0	14,365	6,2
-20,0	7,7470	5,2	5,9540	4,6	9,2353	5,6	10,629	6,0
-15,0	5,7897	5,0	4,7520	4,4	7,0079	5,4	7,9249	5,8
-10,0	4,5234	4,9	3,8214	4,3	5,3654	5,4	5,9641	5,6
- 5,0	3,5643	4,7	3,0954	4,1	4,1260	5,2	4,5098	5,5
0,0	2,8316	4,5	2,5247	4,0	3,2000	5,0	3,4405	5,3
5,0	2,2671	4,4	2,0728	3,9	2,4986	4,9	2,6434	5,1
10,0	1,8287	4,2	1,7125	3,8	1,9662	4,7	2,0475	5,0
15,0	1,4855	4,1	1,4233	3,6	1,5596	4,6	1,6005	4,9
20,0	1,2149	4,0	1,1898	3,5	1,2457	4,5	1,2600	4,7
25,0	1,0000	3,8	1,0000	3,4	1,0000	4,4	1,0000	4,6
30,0	0,82816	3,7	0,84489	3,3	0,80355	4,2	0,79511	4,5
35,0	0,68985	3,6	0,71742	3,2	0,65346	4,1	0,63773	4,4
40,0	0,57784	3,5	0,61208	3,1	0,53456	4,0	0,51454	4,2
45,0	0,48658	3,4	0,52460	3,0	0,43966	3,9	0,41764	4,1
50,0	0,41181	3,3	0,45158	3,0	0,36357	3,8	0,34080	4,0
55,0	0,35020	3,2	0,39036	2,9	0,30183	3,7	0,27970	3,9
60,0	0,29918	3,1	0,33879	2,8	0,25189	3,6	0,23063	3,8
65,0	0,25672	3,0	0,29515	2,7	0,21136	3,5	0,19082	3,7
70,0	0,22120	2,9	0,25809	2,6	0,17819	3,4	0,15857	3,6
75,0	0,19136	2,9	0,22647	2,6	0,15089	3,3	0,13242	3,6
80,0	0,16618	2,8	0,19940	2,5	0,12833	3,2	0,11104	3,5
85,0	0,14484	2,7	0,17614	2,4	0,10948	3,1	0,093483	3,4
90,0	0,12668	2,7	0,15608	2,4	0,093748	3,0	0,079004	3,3
95,0	0,11117	2,6	0,13871	2,3	0,080764	2,9	0,066980	3,2
100,0	0,097870	2,5	0,12364	2,3	0,069842	2,9	0,056982	3,2
105,0	0,086428	2,5	0,11051	2,2	0,060455	2,9	0,048754	3,1
110,0	0,076549	2,4	0,099035	2,2	0,052498	2,8	0,041857	3,0
115,0	0,067992	2,3	0,088982	2,1	0,045740	2,7	0,036019	3,0
120,0	0,060555	2,3	0,080147	2,1	0,039972	2,7	0,031090	2,9
125,0	0,054073	2,2	0,072362	2,0	0,034984	2,6	0,027004	2,8
130,0	0,048407	2,2	0,065484	2,0	0,030700	2,5	0,023528	2,8
135,0	0,043439	2,1	0,059391	1,9	0,027100	2,5	0,020474	2,7

Standardized R/T Characteristics

Number	3206		3207		4001		4002	
T (°C)	$B_{25/100} = 3450$ K		$B_{25/100} = 3100$ K		$B_{25/100} = 3950$ K		$B_{25/100} = 4250$ K	
	R_T/R_{25}	α (%/K)	R_T/R_{25}	α (%/K)	R_T/R_{25}	α (%/K)	R_T/R_{25}	α (%/K)
140,0	0,039072	2,1	0,053981	1,9	0,023986	2,5	0,017863	2,7
145,0	0,035233	2,1	0,049166	1,8	0,021230	2,4	0,015643	2,6
150,0	0,031822	2,0	0,044870	1,8	0,018835	2,3	0,013732	2,6
155,0	0,028809	2,0	0,041028	1,8	0,016787	2,3	0,012095	2,5
160,0	0,026135	1,9	0,037586	1,7	0,015002	2,2	0,010686	2,5
165,0	0,023754	1,9	0,034494	1,7	0,013443	2,2	0,0094683	2,4
170,0	0,021631	1,9	0,031713	1,7	0,012077	2,1	0,0084143	2,4
175,0	0,019734	1,8	0,029205	1,6	0,010877	2,1	0,0074994	2,3
180,0	0,018034	1,8	0,026940	1,6	0,0098217	2,1	0,0067034	2,3
185,0	–	–	–	–	–	–	0,0059662	2,2
190,0	–	–	–	–	–	–	0,0053435	2,2
195,0	–	–	–	–	–	–	0,0047958	2,1
200,0	–	–	–	–	–	–	0,0043128	2,1

Standardized R/T Characteristics

Number	4003		4005		4901		8001	
T (°C)	$B_{25/100} = 4450$ K		$B_{25/100} = 3950$ K		$B_{25/100} = 3950$ K		$B_{25/100} = 4284$ K	
	R_T/R_{25}	α (%/K)	R_T/R_{25}	α (%/K)	R_T/R_{25}	α (%/K)	R_T/R_{25}	α (%/K)
-55,0	103,81	6,8	88,674	7,3	87,890	7,1	-	-
-50,0	73,707	6,7	62,082	7,0	61,759	6,9	-	-
-45,0	52,723	6,6	44,025	6,8	43,934	6,7	-	-
-40,0	37,988	6,5	31,598	6,5	31,618	6,5	- 40,70	7,0
-35,0	27,565	6,4	22,939	6,3	23,006	6,3	28,91	6,7
-30,0	20,142	6,2	16,834	6,1	16,915	6,1	20,78	6,6
-25,0	14,801	6,1	12,481	5,9	12,555	5,9	15,06	6,3
-20,0	10,976	5,9	9,3437	5,7	9,4143	5,7	11,03	6,1
-15,0	8,1744	5,8	7,0603	5,5	7,1172	5,5	8,175	5,9
-10,0	6,1407	5,7	5,3823	5,3	5,4308	5,4	6,119	5,8
- 5,0	4,6331	5,5	4,1378	5,2	4,1505	5,2	4,614	5,6
0,0	3,5243	5,4	3,2068	5,0	3,2014	5,0	3,510	5,4
5,0	2,6995	5,3	2,5045	4,9	2,5011	4,9	2,690	5,3
10,0	2,0831	5,1	1,9704	4,7	1,9691	4,7	2,078	5,1
15,0	1,6189	5,0	1,5613	4,6	1,5618	4,6	1,617	5,0
20,0	1,2666	4,9	1,2455	4,5	1,2474	4,5	1,267	4,8
25,0	1,0000	4,7	1,0000	4,3	1,0000	4,3	1,000	4,7
30,0	0,78351	4,6	0,80793	4,2	0,80800	4,2	0,7942	4,6
35,0	0,62372	4,5	0,65667	4,1	0,65690	4,1	0,6347	4,4
40,0	0,49937	4,4	0,53680	4,0	0,53720	4,0	0,5105	4,3
45,0	0,40218	4,3	0,44125	3,9	0,44235	3,9	0,4129	4,2
50,0	0,32557	4,2	0,36463	3,8	0,36610	3,8	0,3359	4,1
55,0	0,26402	4,1	0,30287	3,7	0,30393	3,7	0,2747	4,0
60,0	0,21527	4,0	0,25280	3,6	0,25359	3,6	0,2259	3,9
65,0	0,17693	3,9	0,21202	3,5	0,21283	3,5	0,1867	3,8
70,0	0,14616	3,8	0,17862	3,4	0,17942	3,4	0,1550	3,7
75,0	0,12097	3,7	0,15116	3,3	0,15183	3,3	0,1293	3,6
80,0	0,10053	3,7	0,12845	3,2	0,12901	3,2	0,1084	3,5
85,0	0,083761	3,6	0,10961	3,1	0,11002	3,1	0,09122	3,4
90,0	0,070039	3,5	0,093899	3,1	0,094179	3,1	0,07708	3,3
95,0	0,058937	3,4	0,080747	3,0	0,080896	3,0	0,06540	3,3
100,0	0,049777	3,4	0,069694	2,9	0,069722	2,9	0,05569	3,2
105,0	0,042146	3,3	0,060367	2,8	0,060397	2,8	0,04764	3,1
110,0	0,035803	3,2	0,052469	2,8	0,052493	2,9	0,04090	3,0
115,0	0,030504	3,2	0,045755	2,7	0,045733	2,7	0,03523	3,0
120,0	0,026067	3,1	0,040029	2,6	0,039963	2,7	0,03045	2,9
125,0	0,022332	3,0	0,035128	2,6	0,035059	2,6	0,02640	2,6
130,0	0,019186	3,0	0,030920	2,5	0,030844	2,6	0,02297	2,8
135,0	0,016515	2,9	0,027295	2,5	0,027192	2,5	0,02004	2,7

Standardized R/T Characteristics

Number	4003		4005		4901		8001	
T (°C)	$B_{25/100} = 4450$ K		$B_{25/100} = 3950$ K		$B_{25/100} = 3950$ K		$B_{25/100} = 4284$ K	
	R_T/R_{25}	α (%/K)	R_T/R_{25}	α (%/K)	R_T/R_{25}	α (%/K)	R_T/R_{25}	α (%/K)
140,0	0,014253	2,9	0,024163	2,4	0,024034	2,4	0,01754	2,6
145,0	0,012367	2,8	0,021448	2,4	0,021285	2,4	0,01540	2,6
150,0	0,010758	2,8	0,019089	2,3	0,018895	2,4	0,01355	2,5
155,0	0,0093933	2,7	0,017032	2,3	0,016813	2,3	0,01196	2,5
160,0	0,0082272	2,7	0,015235	2,2	0,014991	2,3	0,01059	2,4
165,0	0,0072270	2,6	0,013660	2,2	0,013394	2,2	0,009398	2,4
170,0	0,0063661	2,6	0,012277	2,1	0,011991	2,2	0,008359	2,3
175,0	0,0056228	2,5	0,011058	2,1	0,010754	2,1	0,007453	2,3
180,0	0,0049790	2,5	0,0099824	2,0	0,0096629	2,1	0,006659	2,2
185,0	0,0043780	2,4	0,0090304	2,0	0,0087387	2,1	0,005966	2,2
190,0	0,0038791	2,4	0,0081861	1,9	0,0078933	2,0	0,005357	2,1
195,0	0,0034441	2,4	0,0074355	1,9	0,0071428	2,0	0,004819	2,1
200,0	0,0030639	2,3	0,0067669	1,9	0,0064752	1,9	0,004344	2,0
205,0	–	–	0,0061700	1,8	–	–	0,003925	2,0
210,0	–	–	0,0056361	1,8	–	–	0,003553	2,0
215,0	–	–	0,0051576	1,8	–	–	0,003222	1,9
220,0	–	–	0,0047278	1,7	–	–	0,002927	1,9
225,0	–	–	0,0043412	1,7	–	–	0,002665	1,9
230,0	–	–	0,0039927	1,7	–	–	0,002430	1,8
235,0	–	–	0,0036780	1,6	–	–	0,002219	1,8
240,0	–	–	0,0033934	1,6	–	–	0,002030	1,8
245,0	–	–	0,0031355	1,6	–	–	0,001861	1,7
250,0	–	–	0,0029015	1,5	–	–	0,001708	1,7
255,0	–	–	0,0026888	1,5	–	–	0,001570	1,7
260,0	–	–	0,0024951	1,5	–	–	0,001445	1,6
265,0	–	–	0,0023185	1,5	–	–	0,001332	1,6
270,0	–	–	0,0021572	1,4	–	–	0,001230	1,6
275,0	–	–	0,0020098	1,4	–	–	0,001138	1,6
280,0	–	–	0,0018747	1,4	–	–	0,001053	1,5
285,0	–	–	0,0017509	1,4	–	–	0,0009764	1,5
290,0	–	–	0,0016372	1,3	–	–	0,0009065	1,5
295,0	–	–	0,0015326	1,3	–	–	0,0008425	1,5
300,0	–	–	0,0014364	1,3	–	–	0,0007840	1,5
305,0	–	–	0,0013477	1,3	–	–	–	–
310,0	–	–	0,0012658	1,2	–	–	–	–
315,0	–	–	0,0011901	1,2	–	–	–	–
320,0	–	–	0,0011201	1,2	–	–	–	–
325,0	–	–	0,0010553	1,2	–	–	–	–
330,0	–	–	0,00099521	1,2	–	–	–	–
335,0	–	–	0,00093943	1,1	–	–	–	–
340,0	–	–	0,00088760	1,1	–	–	–	–
345,0	–	–	0,00083939	1,1	–	–	–	–
350,0	–	–	0,00079450	1,1	–	–	–	–

Standardized R/T Characteristics

Number	8010		8016		8018	
T (°C)	$B_{25/100} = 3474$ K		$B_{25/100} = 3988$ K		$B_{25/100} = 3964$ K	
	R_T/R_{25}	α (%/K)	R_T/R_{25}	α (%/K)	R_T/R_{25}	α (%/K)
-55,0	58,25	6,6	96,30	7,4	-	-
-50,0	42,12	6,5	67,01	7,2	-	-
-45,0	30,70	6,2	47,17	6,9	-	-
-40,0	22,66	6,0	33,65	6,7	30,24	6,3
-35,0	16,89	5,8	24,26	6,4	22,10	6,1
-30,0	12,73	5,6	17,70	6,2	16,32	5,9
-25,0	9,683	5,4	13,04	6,0	12,17	5,8
-20,0	7,440	5,2	9,707	5,8	9,153	5,6
-15,0	5,766	5,0	7,293	5,6	6,945	5,4
-10,0	4,510	4,8	5,533	5,5	5,313	5,2
-5,0	3,555	4,7	4,232	5,3	4,097	5,1
0,0	2,825	4,5	3,265	5,1	3,183	4,9
5,0	2,270	4,3	2,539	5,0	2,491	4,8
10,0	1,836	4,3	1,990	4,8	1,963	4,7
15,0	1,489	4,1	1,571	4,7	1,557	4,6
20,0	1,216	4,0	1,249	4,5	1,244	4,4
25,0	1,000	3,8	1,000	4,4	1,000	4,3
30,0	0,8276	3,8	0,8057	4,3	0,8083	4,2
35,0	0,6869	3,7	0,6531	4,1	0,6572	4,1
40,0	0,5736	3,5	0,5327	4,0	0,5373	4,0
45,0	0,4817	3,4	0,4369	3,9	0,4418	3,9
50,0	0,4067	3,3	0,3603	3,8	0,3650	3,7
55,0	0,3455	3,2	0,2986	3,7	0,3030	3,7
60,0	0,2949	3,1	0,2488	3,6	0,2527	3,6
65,0	0,2528	3,0	0,2083	3,5	0,2118	3,5
70,0	0,2177	3,0	0,1752	3,4	0,1783	3,4
75,0	0,1882	2,9	0,1481	3,3	0,1508	3,3
80,0	0,1634	2,8	0,1258	3,2	0,1280	3,2
85,0	0,1424	2,7	0,1072	3,2	0,1091	3,2
90,0	0,1245	2,7	0,09177	3,1	0,09330	3,1
95,0	0,1092	2,6	0,07885	3,0	0,08016	3,0
100,0	0,09614	2,5	0,06800	2,9	0,06910	2,9
105,0	0,08491	2,5	0,05886	2,9	0,05974	2,9
110,0	0,07523	2,4	0,05112	2,8	0,05183	2,8
115,0	0,06685	2,3	0,04454	2,7	0,04512	2,8
120,0	0,05958	2,3	0,03893	2,6	0,03940	2,7
125,0	0,05325	2,2	0,03417	2,6	0,03450	2,6
130,0	0,04772	2,2	0,03009	2,5	0,03032	2,6
135,0	0,04288	2,1	0,02654	2,5	0,02672	2,5

Standardized R/T Characteristics

Number	8010		8016		8018	
T (°C)	$B_{25/100} = 3474$ K		$B_{25/100} = 3988$ K		$B_{25/100} = 3964$ K	
	R_T/R_{25}	α (%/K)	R_T/R_{25}	α (%/K)	R_T/R_{25}	α (%/K)
140,0	0,03862	2,1	0,02348	2,4	0,02361	2,5
145,0	0,03487	2,0	0,02083	2,4	0,02091	2,4
150,0	0,03155	2,0	0,01853	2,3	0,01857	2,4
155,0	0,02862	1,9	0,01653	2,3	—	—
160,0	0,02602	1,9	0,01479	2,2	—	—
165,0	0,02371	1,8	0,01326	2,2	—	—
170,0	0,02164	1,8	0,01191	2,1	—	—
175,0	0,01979	1,8	0,01073	2,1	—	—
180,0	0,01814	1,7	0,009681	2,0	—	—
185,0	0,01665	1,7	0,008758	2,0	—	—
190,0	0,01532	1,7	0,007938	1,9	—	—
195,0	0,01411	1,6	0,007209	1,9	—	—
200,0	0,01302	1,6	0,006559	1,9	—	—
205,0	0,01204	1,6	0,005981	1,8	—	—
210,0	0,01115	1,5	0,005463	1,8	—	—
215,0	0,01034	1,5	0,004998	1,8	—	—
220,0	0,009602	1,5	0,004581	1,7	—	—
225,0	0,008931	1,4	0,004206	1,7	—	—
230,0	0,008319	1,4	0,003868	1,7	—	—
235,0	0,007759	1,4	0,003563	1,6	—	—
240,0	0,007246	1,4	0,003286	1,6	—	—
245,0	0,006776	1,3	0,003036	1,6	—	—
250,0	0,006345	1,3	0,002809	1,5	—	—
255,0	0,005948	1,3	0,002603	1,5	—	—
260,0	0,005583	1,3	0,002415	1,5	—	—
265,0	0,005247	1,2	0,002244	1,5	—	—
270,0	0,004936	1,2	0,002088	1,4	—	—
275,0	0,004649	1,2	0,001945	1,4	—	—
280,0	0,004383	1,2	0,001814	1,4	—	—
285,0	0,004137	1,1	0,001694	1,4	—	—
290,0	0,003909	1,1	0,001584	1,3	—	—
295,0	0,003696	1,1	0,001483	1,3	—	—
300,0	0,003499	1,1	0,001390	1,3	—	—



Siemens Matsushita Components

Ceramic chip capacitors from stock

Small in size, big in performance

Our selection of capacitors ranges from standard sizes down to a miniature highlight in 0402 style. Measuring only 1 x 0.5 x 0.5 mm, it's an ideal solution for applications where space is tight, like in handies and cardiac pacemakers. At the same time all our chips can boast excellent soldering characteristics, with special terminal variants for conductive adhesion. And we also thought about the right packing for automatic placement. You get all sizes down to 1206 in bulk case for example, plus voltage ratings from 16 to 500 V. By the way, our leaded models have CECC approval of course, in fact they were certified more than ten years ago.

More in the new short form catalog!



SCS - dependable, fast and competent

Mounting Instructions

1 Soldering

1.1 Leaded NTC thermistors

Leaded thermistors comply with the solderability requirements specified by CECC.

When soldering, care must be taken that the NTC thermistors are not damaged by excessive heat. The following maximum temperatures, maximum time spans and minimum distances have to be observed:

	<i>Dip soldering</i>	<i>Iron soldering</i>
Bath temperature	max. 260 °C	max. 360 °C
Soldering time	max. 4 s	max. 2 s
Distance from thermistor	min. 6 mm	min. 6 mm

Under more severe soldering conditions the resistance may change.

1.2 Leadless NTC thermistors

In case of NTC thermistors without leads, soldering is restricted to devices which are provided with a solderable metallization. The temperature shock caused by the application of hot solder may produce fine cracks in the ceramic, resulting in changes in resistance.

To prevent leaching of the metallization, solder with silver additives or with a low tin content should be used. In addition, soldering methods should be employed which permit short soldering times.

1.3 SMD NTC thermistors

The notes on soldering leadless thermistors also apply to the SMD versions (see IEC 68-2-58).

1.3.1 Wettability test in accordance with IEC 68-2-58

Preconditioning: Immersion into flux F-SW 32.

Evaluation criterion: Wetting of soldering areas $\geq 95\%$.

	Termination	Solder	Bath temperature (°C)	Dwell time (s)
NTC	AgPd	SnPb 60/40	215 ± 3	4

Mounting Instructions

1.3.2 Soldering heat resistance test in accordance with IEC 68-2-58

Preconditioning: Immersion into flux F-SW 32.

Evaluation criterion: Leaching of side edges $\leq 1/3$.

	Termination	Solder	Bath temperature (°C)	Dwell time (s)
NTC	AgPd	SnPb 60/40	260 ± 5	10

1.3.3 Recommended soldering temperature profiles

Vapor phase soldering

Temperature/time diagram for vapor phase soldering, in-line system with preheating. The temperatures stated refer to the component terminals.

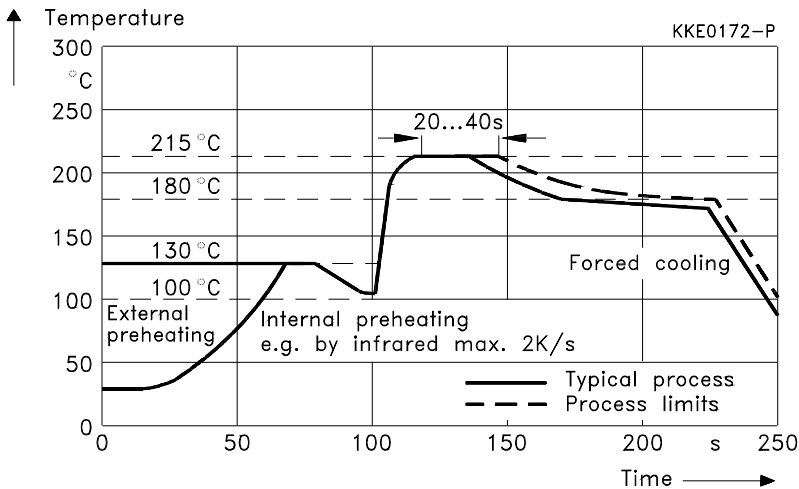

Wave soldering

Temperature on the component terminals during dual wave soldering

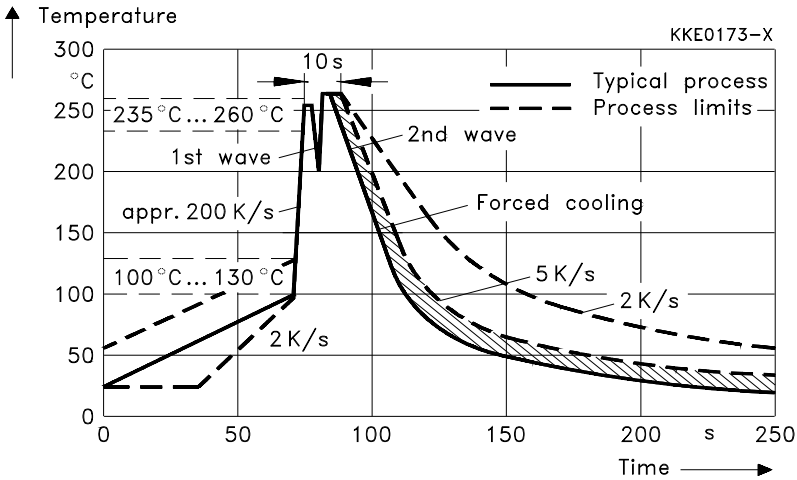

Infrared soldering

Temperature on the component terminals during infrared soldering

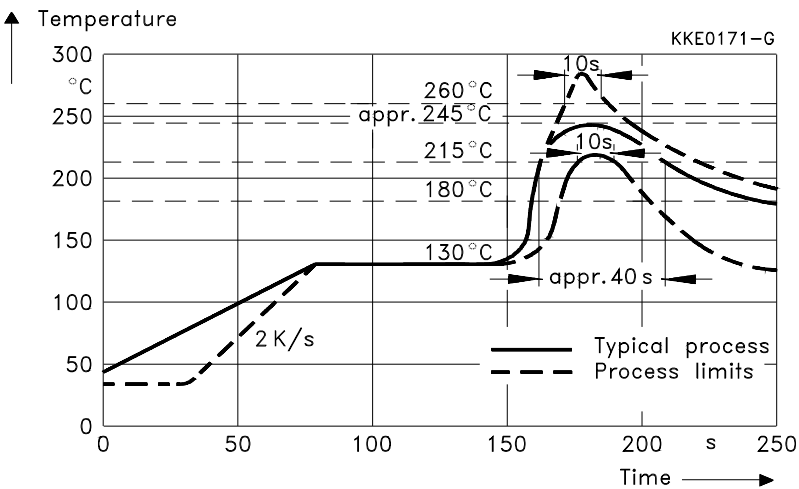

Mounting Instructions

1.3.4 Notes

Iron soldering should be avoided, hot air methods are recommended for repair purposes.

2 Conductive adhesion

An alternative to soldering is the gluing of thermistors with conductive adhesives. The benefit of this method is that it involves no thermal stress. The adhesives used must be chemically inert.

3 Clamp contacting

Pressure contacting by means of clamps is particularly suitable for applications involving frequent switching and high turn-on powers.

4 Robustness of terminations

The leads meet the requirements of IEC 68-2-21. They may not be bent closer than 4 mm from the solder joint on the thermistor body or from the point at which they leave the feed-throughs. During bending, any mechanical stress at the outlet of the leads must be removed. The bending radius should be at least 0,75 mm.

Tensile strength: Test Ua1:
Leads $\varnothing \leq 0,5 \text{ mm} = 5 \text{ N}$
 $\varnothing > 0,5 \text{ mm} = 10 \text{ N}$

Bending strength: Test Ub:
Two 90°-bends in opposite directions at a weight of 0,25 kg.

Torsional strength: Test Uc: severity 2
The lead is bent by 90° at a distance of 6 to 6,5 mm from the thermistor body.
The bending radius of the leads should be approx. 0,75 mm. Two torsions of 180° each (severity 2).

When subjecting leads to mechanical stress, the following should be observed:

Tensile stress on leads

During mounting and operation tensile forces on the leads are to be avoided.

Bending of leads

Bending of the leads directly on the thermistor body is not permissible.

A lead may be bent at a minimum distance of twice the wire's diameter + 2 mm from the solder joint on the thermistor body. During bending the wire must be mechanically relieved at its outlet. The bending radius should be at least 0,75 mm.

Twisting of leads

The twisting (torsion) by 180° of a lead bent by 90° is permissible at 6 mm from the bottom of the thermistor body.

5 Sealing and potting

When thermistors are sealed or potted, there must be no mechanical stress through differing thermal expansion in the curing process and during later operation. In the curing process the upper category temperature of the thermistor must not be exceeded. It is also necessary to ensure that the potting compound is chemically neutral.

6 Cleaning

If cleaning is necessary, mild cleaning agents such as freon, trichloroethane and perchloroethylene are recommended. Ultrasonic cleaning methods are permissible.

7 Storage

In order to maintain their solderability, thermistors must be stored in a non-corrosive atmosphere. Humidity, temperature and container materials are critical factors.

If possible, the components should be left in the original packing. Touching the metallization of unsoldered thermistors may change their soldering properties.



Siemens Matsushita Components

Ferrite cores and accessories

In place, in shape

With more than 4000 different ferrite cores we have the solution to tackle every application. Straight from SCS stock we can supply you 12 core shapes in as many as 26 materials, plus the matching accessories:

- ▶ **RM** for transformers with high packing density
- ▶ **PM** for power transformers
- ▶ **P** for transformers with extremely low leakage field
- ▶ **E cores**
ETD, EC, ER with round center leg for compact transformers, EFD with flattened center leg for ultra flat transformers, wide range of standard E cores
- ▶ **U** for storage chokes, split diode and line transformers
- ▶ **Ring** for pulse, broadband and balun transformers plus chokes
- ▶ **Double-aperture** for broadband transformers up into the GHz region

SCS – dependable, fast and competent

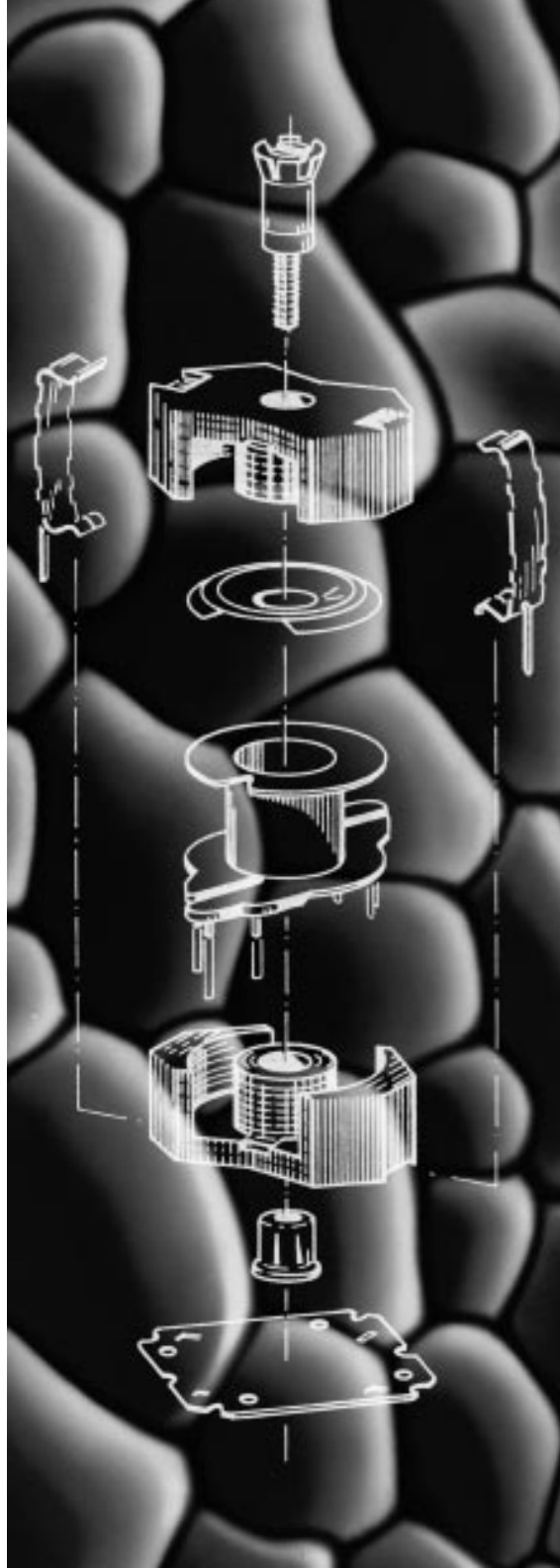

1 Manufacturing process and quality assurance

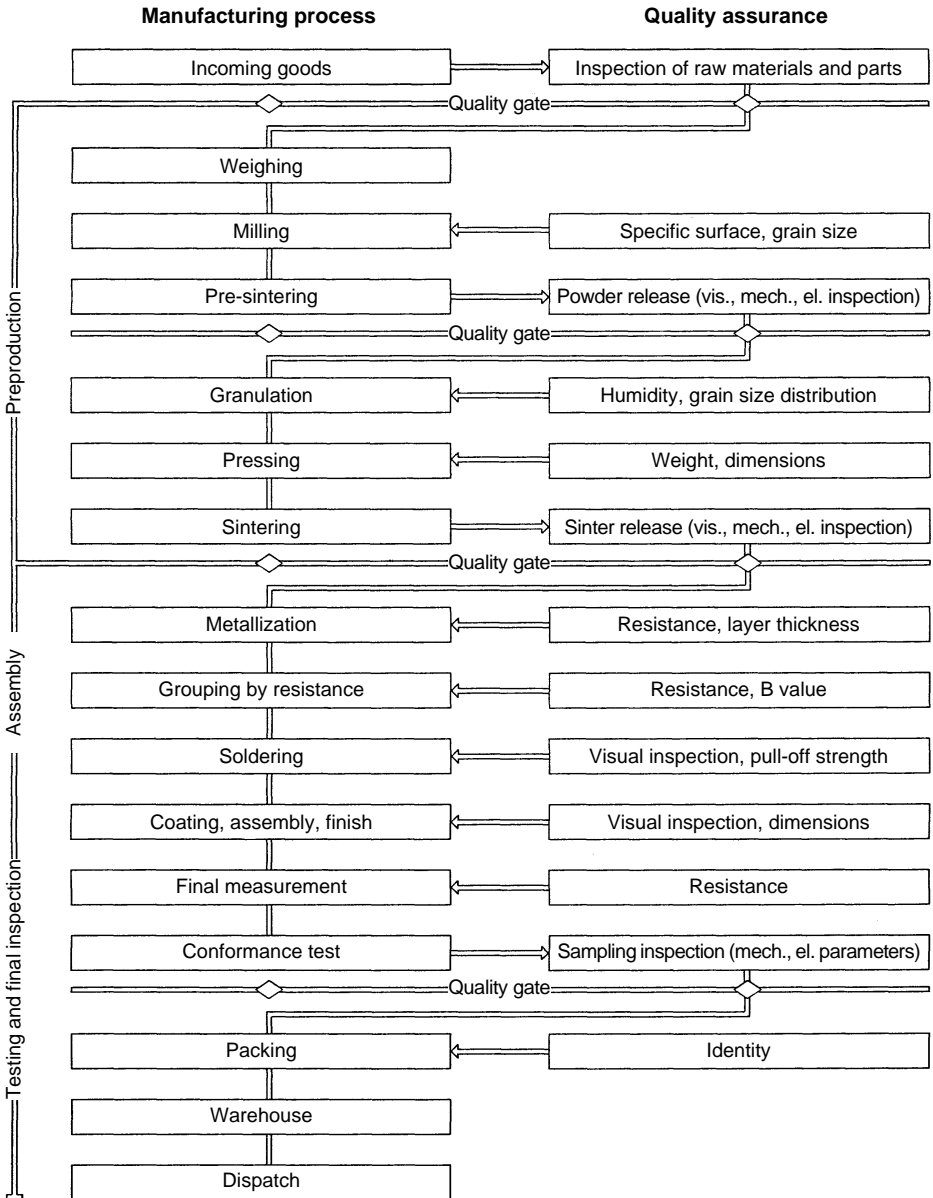

Quality

2 General

S+M has set up extensive quality assurance systems in order to meet the stringent technical demands of an open world market. These systems follow the CECC ISO-9000 to ISO-9004 standards. Our QA system received the ISO 9001 certificate in September 1991.

3 Sequence of quality assurance measures

The quality department tested and released the thermistors described in this data book on the basis of the following criteria: compliance with type specifications, process capability of production equipment as well as accuracy of measuring and test methods and equipment.

To ensure a constantly high quality level, the following tests are carried out:

3.1 Incoming inspection

The parts and materials required for production are checked for dimensional accuracy and material properties in a prescribed sequence.

3.2 Process assurance

To achieve the objective of eliminating defects as efficiently as possible and at their very source, quite different measures are taken. Modern quality tools such as FMEA (Failure Mode and Effect Analysis) are used already during the starting phase: A risk-priority figure is assigned to *potential* defects according to their significance as well as to the probability of occurrence and detection. In case of high risk-priority figures, remedial measures are taken from the beginning. During production all essential processes are subject to statistical process control (SPC).

3.3 Product assurance

Each manufacturing stage is followed by a so-called "quality control gate", i.e. the product is only released for the next stage after passing a corresponding test. The test results are constantly monitored and evaluated and are then used to assess the quality of the manufacturing process itself (refer to 3.2).

3.4 Final inspection

Final measurements and conformance tests ensure that delivery quality is kept constant within defined tolerances.

4 Delivery quality

The term delivery quality designates the conformance with agreed data at the time of delivery.

5 Sampling inspection

The customer may carry out incoming inspections which are subject to standardized sampling inspection plans specifying the acceptance or rejection of a delivery lot in conjunction with agreed AQL values (AQL = acceptable quality level).

The scope and the maximum permissible number of defects of a sampling inspection are specified in IEC 410 (identical with MIL-STD 105 D and DIN ISO 2859-1), single sampling plan for normal inspection, inspection level II. The sampling instructions of this standard are such that a delivered lot will be accepted with a high degree of probability (greater than 90 %), if the percentage of defectives does not exceed the specified AQL level.

Generally, the average defect percentage of our deliveries lies clearly below the AQL value. This is ensured by appropriate quality assurance measures in the manufacturing plants and substantiated by the final inspections.

6 Classification of defects

A component is considered defective if it does not comply with the specifications stated in the data sheets or in an agreed delivery specification. Defects which generally exclude the functional use of the component (inoperatives) are classified separately from less significant defects.

Inoperatives of thermistors are:

- Short circuit or open circuit
- Component, case, terminals or encapsulation broken
- Incorrect marking
- Mixing of different types

Other defects are:

- Electrical defects (maximum ratings are exceeded)
- Mechanical defects, e. g. incorrect dimensions, damaged housings, illegible marking, twisted leads

7 AQL values

The following AQL values apply to the quoted defects

- | | |
|---|-------|
| – for inoperatives (electrical and mechanical) | 0,065 |
| – for the total number of electrical defectives | 0,250 |
| – for the total number of mechanical defectives | 0,250 |

The values for the total number of defectives include related inoperatives.

Quality

8 Incoming inspection by the customer

The quality of our products is ensured by the QA measures assigned to the individual production stages as shown [on page 145](#). Thus the customer can do away with cost-intensive incoming inspections. If a customer wishes nevertheless to carry out an incoming inspection, we recommend that the inspection plan shown below is used. The inspection methods employed must in this case be agreed upon between customer and supplier. In many cases a stricter inspection method is agreed upon to the effect that the sample size corresponds to the plan, the required inspection, however, demands “zero defects”, i. e. a lot will only be accepted if the samples are free from defects. Regardless of that, all sample tests carried out at S+M are subject to these stricter test conditions (zero defects).

The following information is required for the assessment of possible claims: test circuit, sample size, number of defectives found, sample defectives and packing slip, delivery note number, lot number and/or label.

Sampling plan for normal inspection – inspection level II

in accordance with DIN 40 080 (contents correspond to MIL Std 105 LD and IEC 410)

Sampling inspection plan		AQL			
		0,065	0,100	0,250	0,400
N = Lot size					
2 ...	50	N	N	N	N or 32-0
51 ...	90	N	N	50-0	32-0
91 ...	150	N	N or 125-0	50-0	32-0
151 ...	280	N or 200-0	125-0	50-0	32-0
281 ...	500	200-0	125-0	50-0	32-0
501 ...	1 200	200-0	125-0	50-0	125-1
1 201 ...	3 200	200-0	125-0	200-1	125-1
3 201 ...	10 000	200-0	125-0	200-1	200-2
10 001 ...	35 000	200-0	500-1	315-2	315-3
35 001 ...	150 000	800-1	500-1	500-3	500-5
150 001 ...	500 000	800-1	800-2	800-5	800-7
>	500 000	1250-2	1250-3	1250-7	1250-10

Columns 2 to 5: Left figure = sample size
 Right figure = permissible defects

Additional condition:

As an acceptance number of 0 and a rejection number of 1 provides only limited information on the actual AQL, the next higher sample size should be taken.

9 Reliability

We conduct a large variety of endurance trials and environmental tests to assure the reliability of PTC thermistors. These tests derive from the extremes of expected application conditions, with extra tightening of the conditions so that significant results can be obtained within a reasonable amount of time.

The reliability testing programs of S + M are based on the test plans of relevant CECC standards for assessing the quality of electronic components. Environmental tests are conducted according to IEC 68-2 (Electrical Engineering, Basic Environmental Testing Procedures).

S + M performs reliability tests both in qualifying new component families as well as for periodic requalification. Reliability figures for various component series can be found in the data sheets.

10 Identification and traceability

On the packaging of all shipped thermistors you will find a bar code label stating type, part number, quantity, date of manufacture and lot number. These details are necessary for speedy and informative handling of returns.

This systematic and unmistakable form of identification means that each component can be traced to a certain production lot. This in turn permits retracing back through the entire fabrication process as far as raw materials purchasing.

Example:

(X):94645626

HEISSLEITER 3X2,5 GURT

Type → S153/4,7/M

Part number → (L):B57153-S479-M LOS-NR: 4711 ← Lot number

Quantity → (Q):01500 (D):93033 ← Date of manufacture

MADE IN AUSTRIA

YYCWD
 YY ... Year
 CW ... Calendar week
 D ... Tag
 e.g. 1 ≙ Monday

TNT0364-V

11 Supplementary information

The issuing of quality data – which always relate to a large number of components – is no assurance of characteristics in a legal sense. But an agreement on such data does not exclude the customer's right to claim replacement of individual defective NTC thermistors within the terms of delivery. We cannot assume any further liability, especially for the consequences of component failure.

You should also remember that figures for failure rate refer to an average fabrication situation and are therefore to be understood as mean values (statistical expectations) for a large number of delivery lots of homogeneous NTC thermistors. They are based on application experience as well as on data derived from preceding inspection under normal or – for the purpose of acceleration – tightened conditions.

Environmental Protection Measures

Siemens Matsushita Components GmbH & Co. KG (S + M Components for short) is responsible for protection of the environment in the development, fabrication and use of its products for the intended purpose. S + M Components is very thorough in fulfilling the resulting obligations. Over and above the legal prescriptions, our guiding principle here is the corporation's responsibility towards man and environment.

Responsibility for safety in working with materials that have a potential environmental impact is in the hands of the various managers. This involves, in the first place, instructing and informing the staff concerned. A specially trained environmental protection supervisor watches over adherence to regulations, reports on the introduction of processes within an environmental context and on decisions relating to investment (e.g. he checks that all environmentally associated requirements like filters and sumps have been considered). But advising and informing staff take on the highest priority; this is the only way to ensure that all protective measures are known and observed.

All chemicals employed in development and fabrication are examined for environmental compatibility or harmful effects *before* their use on the basis of DIN safety specifications. Alternatives are devised if risks emerge. The result of this procedure is that today all CFCs as well as all highly toxic materials have been eliminated entirely from the fabrication process.

Dust and vapor generated during fabrication are filtered away for disposal. The emission figures of the filters are constantly examined; considerable efforts are undertaken to ensure that these figures are well below the legally prescribed limits. The same applies to the water used in a plant. This being cleansed in a special waste-water treatment process. Water consumption has been reduced substantially in recent years through the use of cooling water circuits and water recycling.

Waste produced in the fabrication of components is sorted and collected on the spot and recycled by state-of-the-art methods.

The packaging material used for our components can be fully recycled.

All NTC thermistors can be disposed of on a dump for industrial waste that is similar to household refuse without any special precautions.

Of course, we are still by no means satisfied with what we have already achieved, and more steps are due to follow in the interest of further reducing and ultimately eliminating entirely all environmental impact created in the development and fabrication of our components.



Siemens Matsushita Components

New lab assortments in film capacitors

Five at a stroke

To save you the trouble of inquiring for individual ratings to put into your design, there are now five practical sets of film capacitors:

- ▶ **Lead spacing 5:** 525 types, 50 to 400 V, 1 nF to 3.3 μ F
- ▶ **SilverCaps:** the lowest-cost models, low in volume, 63 to 400 V, 1 nF to 10 μ F
- ▶ **MKPs in wound technology:** for RF applications, 250 to 2000 V, 1.5 nF to 0.68 μ F
- ▶ **MKPs in stacked-film technology:** 300 types, 160 to 1000 V, 1.5 nF to 1 μ F
- ▶ **Interference suppression:** 150 types with a wide choice of ratings for different applications – X2 with small dimensions, Safe-X for maximum security against active flammability (X2) and Y for suppressing common-mode interference (Y2)

SCS – dependable, fast and competent



Climatic Conditions

1 Reliability data

For most measuring NTCs and in particular for those featuring high measuring accuracy, reliability data are given in the data sheets. These data provide information on the deviation of rated resistance under high thermal, electrical or mechanical stress.

These resistance tolerances are in the range of a few percent and have therefore no relevance for coarsely tolerated NTC thermistors.

2 Operating temperature range / ambient temperatures

Thermistors are assigned to climatic categories according to the climatic conditions under which they have been tested.

The IEC climatic category is specified for all NTC thermistors in the data sheets. In accordance with IEC 68-1 (Appendix A) the climatic category is made up of three sets of digits, which are decoded as shown in the following example:

Example:

Climatic category

55/085/56

Test A: Cold (lower category temperature)
 – 55 °C _____
 (in accordance with IEC 68-2-1)

Test B: Dry heat (upper category temperature)
 + 85 °C _____
 (in accordance with IEC 68-2-2)

Test C: Damp heat (duration of test)
 56 days _____
 (in accordance with IEC 68-2-3)



Siemens Matsushita Components

A whole lot of ring core chokes

Chokes to your choice

You urgently need particular ring core chokes? That's no problem, we have 200,000 pieces in stock and deliver reliably through SCS. Our automated production guarantees



the best of reliability too. It turns out chokes in different versions: flat and upright, with current rated from 0.4 to 16 A. UL and VDE approved, and complying with the latest EMC standards of course.

SCS – dependable, fast and competent

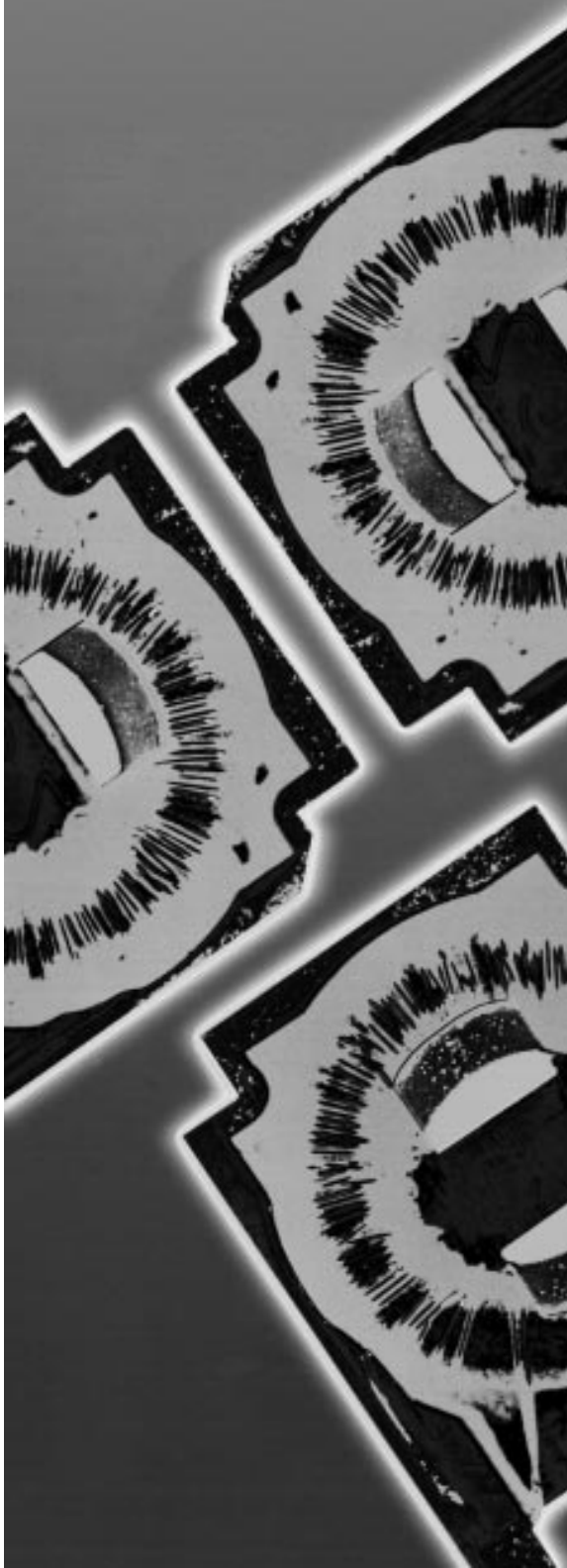

Taping and Packing

Many of the components presented in this data book are suitable for processing on automatic insertion or placement machines. These thermistors can be supplied on tape for easy handling by automatic systems. The individual modes of taping and packing will be described in the following.

1 Taping of SMD thermistors (in accordance with IEC 286-3)

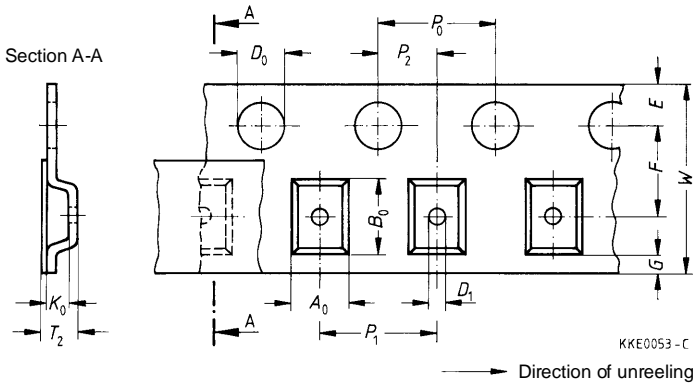

Dimension (mm)	Size (8 mm tape)		Tolerance
	0805	1206	
$A_0 \times B_0$	The rated dimensions of the component compartment have been derived from the relevant component specification and are chosen such that the components cannot change their orientation within the tape.		
K_0			
T_2			
D_0	1,50		+ 0,10 / - 0
D_1	1,00		min.
P_0	4,00		$\pm 0,10^{1)}$
P_2	2,00		$\pm 0,05$
P_1	4,00		$\pm 0,10$
W	8,00		$\pm 0,30$
E	1,75		$\pm 0,10$
F	3,50		$\pm 0,05$
G	0,75		min.

1) $\leq 0,2$ mm over 10 sprocket holes

Taping and Packing

Reel packing

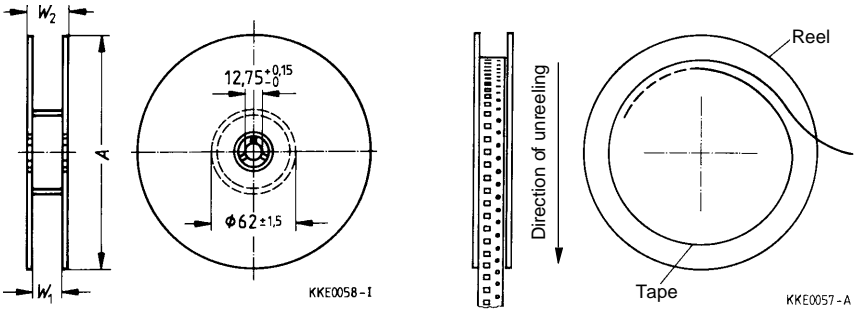

8-mm tape

Dimension	180-mm reel
A	180 - 2/+ 0
W_1	8,4 + 1,5/- 0
W_2	14,4 max.

2 Taping of radial-lead NTC thermistors

Dimensions and tolerances (taping in accordance with IEC 286-2)

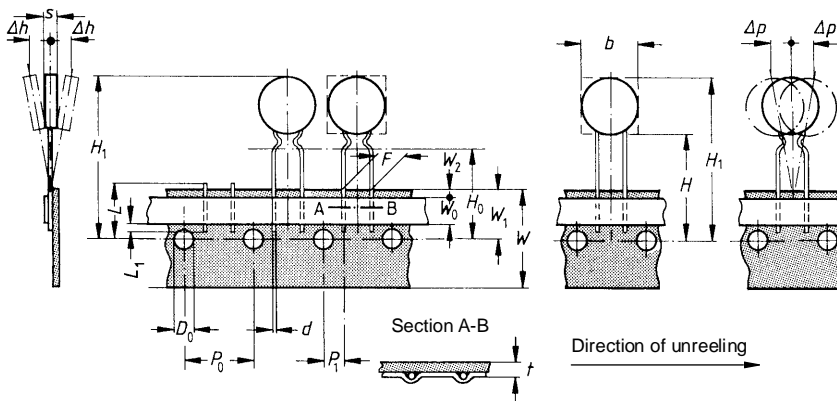

TNT0219-U

Dimension (mm)	Lead spacing 2,54 mm	Lead spacing 5,08 mm	Tolerance of lead spacing 2,54/5,08 mm	Lead spacing 7,5 mm	Tolerance of lead spacing 7,5 mm	Remarks
b	11,0	11,5	max.	21	max.	
s	5,0	6,0	max.	7	max.	
d	0,5/0,6	0,5/0,6	$\pm 0,05$	0,8/1,0	$\pm 0,05$	
P_0	12,7	12,7	$\pm 0,2$	12,7	$\pm 0,3$	$\pm 1 \text{ mm}/20$ sprocket holes
P_1	5,08	3,81	$\pm 0,7$	8,95	$\pm 0,8$	
F	2,54	5,08	$+ 0,6/- 0,1$	7,5	$\pm 0,8$	
Δh	0	0	$\pm 2,0$	0	*)	measured at top of component body
Δp	0	0	$\pm 1,3$	0	$\pm 1,3$	
W	18,0	18,0	$\pm 0,5$	18,0	$\pm 0,5$	
W_0	5,5	5,5	min.	5,5	min.	peel-off force $\geq 5 \text{ N}$
W_1	9,0	9,0	$\pm 0,5$	9,0	$+ 0,75/- 0,5$	
W_2	2,0	2,0	max.	3,0	max.	
H	18,0	18,0	$+ 2,0/- 0$	18,0	$+ 2,0/- 0$	
H_0	16,0	16,0	$\pm 0,5$	16,0	$\pm 0,5$	
H_1	32,2	32,2	max.	45,0	max.	
D_0	4,0	4,0	$\pm 0,2$	4,0	$\pm 0,2$	
t	0,9	0,9	max.	0,9	max.	without wires
L	11,0	11,0	max.	11,0	max.	
L_1	4,0	4,0	max.	4,0	max.	

*) Depends on s

Taping and Packing

Modes of packing

AMMO packing

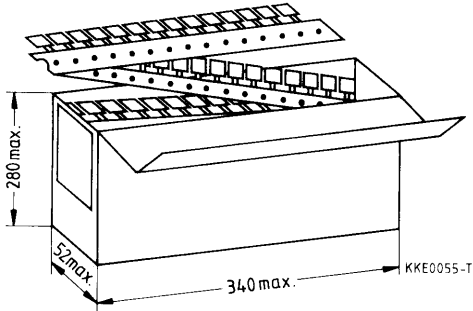

Number of pieces: 1000 ... 2000

Reel packing

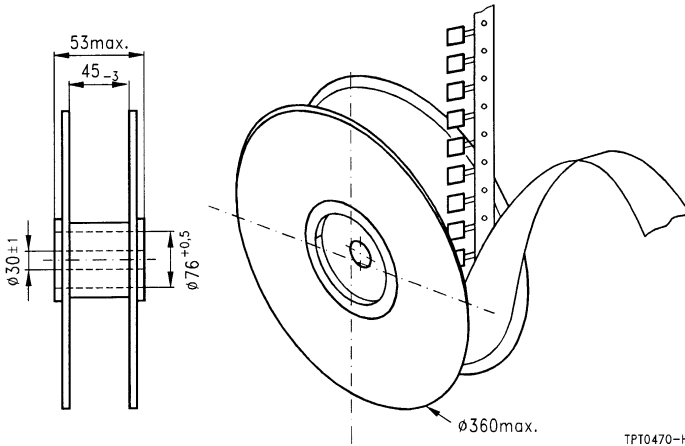

Number of pieces: 1000 ... 2000

Cassette packing

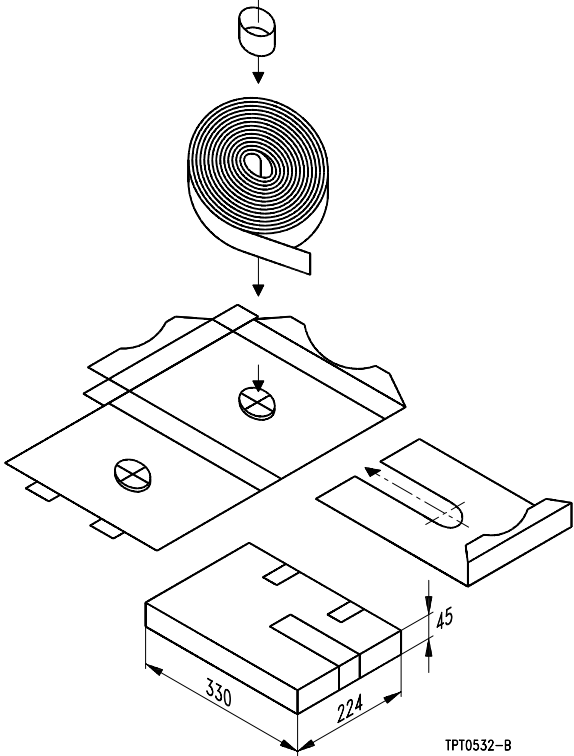

Number of pieces: 1000 ... 2000

Bulk packing

The components are packed in cardboard boxes, the size of which depends on the order quantity.

Taping and Packing

3 Taping of M 87 NTC thermistors

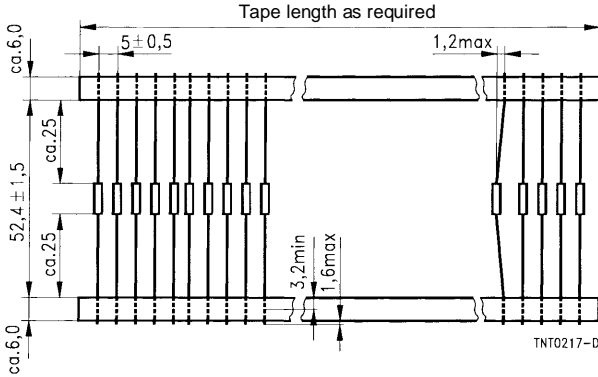

Packing

Reel packing of axial-lead NTC thermistors (with separating paper between tape layers)

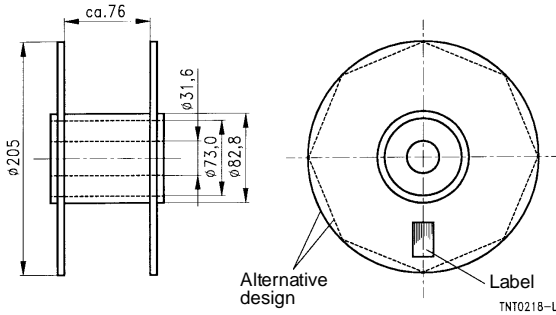

4 Packing codes

The last two digits of the complete ordering code state the packing mode:

40		Bulk	
50	Radial leads, kinked	Tape	Cassette packing
51	Radial leads, kinked	Tape	Reel packing
52	Radial leads, straight	Tape	Cassette packing
53	Radial leads, straight	Tape	Reel packing
54	Radial leads, kinked	Tape	AMMO packing
55	Radial leads, straight	Tape	AMMO packing
62	SMDs	Tape	Reel packing
70	Radial leads	Bulk	Cardboard strips

(If no packing code is indicated, this corresponds to 70)

Example: B57164-K102-J Untaped
 B57164-K102-J52 Taped

Symbols and Terms

A	Area
B	B value
$B_{25/100}$	B value determined by resistance measurement at 25 °C and 100 °C
C_T	Test capacitance
C_{th}	Heat capacity
I	Current
I_{max}	Maximum current within stated temperature range
I_N	Rated current
I_{rms}	Root-mean-square value of current
k	Parameter for calculating the NTC resistance as a function of current (specified for inrush current limiters)
N	Number (integer)
n	Parameter for calculating the NTC resistance as a function of current (specified for inrush current limiters)
P	Power
P_{25}	Maximum power at 25 °C
P_{el}	Electrical power
P_{max}	Maximum power within stated temperature range
$\Delta R_B/R_B$	Resistance tolerance caused by spread of B value
R_N	Rated resistance
$\Delta R_N/R_N$	Resistance tolerance
R_P	Parallel resistance
R_S	Series resistance
R_T	Resistance at temperature T (e.g. R_{25} = resistance at 25 °C)
R_V	Load resistance
T	Temperature
t	Time
T_A	Ambient temperature
t_a	Thermal threshold time
T_N	Rated temperature
t_S	Switching time
T_{surf}	Surface temperature
V	Voltage
V_{is}	Insulation test voltage
V_L	Load voltage
V_{Meas}	Measuring voltage
V_N	Rated voltage
V_{NTC}	Voltage drop across an NTC thermistor
V_{op}	Operating voltage
V_p	Pulse strength
V_{rms}	Root-mean-square value of voltage
α	Temperature coefficient
Δ	Tolerance, change

Symbols and Terms

δ_{th}	Dissipation factor
τ_a	Thermal time constant
τ_c	Thermal cooling time constant
λ	Failure rate

Abbreviations / Notes



Surface-mount devices

* To be replaced by a number in ordering codes, type designations etc.

+ To be replaced by a letter

All dimensions are given in mm.

The commas used in numerical values denote decimal points.

Subject Index

A

ageing 31

B

B value 24

brightness control 34

bypassing 38

C

ceramics 23

clamp contacting 142

cleaning 143

conductive adhesion 142

D

defects 147

derating curve 38

dissipation factor *dth* 30

F

fixed resistors 36

flow rate 30, 42

fuses 35

G

gas analysis 30

H

heat capacity C_{th} 30

I

inrush current limiting 35

L

liquid level sensors 41

load derating 38

load voltage 39

M

media 30

N

NTC 23

NTC resistance 24

O

Ohm's law 29

P

parallel connection 36

point-matching thermistors 25

potting 143

power rating *P* 30

pulse strength V_p 39

Q

quality assurance 145

R

R/T characteristic
linearization 32

radiation measurement 42

relay delay 43

resistance tolerance 26

resistance/temperature relation 24

restart 38

robustness of terminations 142

S

sealing 143

self-heating 23, 37

series connection 36

soldering 139

stability 31

storage 143

T

tank content indication 42

temperature coefficient α 27

temperature compensation 34

temperature controller 35

temperature measurement 32

temperature sensing 32

temperature stabilization 35

temperature tolerance 26

Subject Index

test capacitance	39
thermal cooling time constant τ_c	31
thermal time constant τ_a	31
thermostat	35
tolerance	25

U

uni curve thermistors	25
-----------------------	----

V

vacuum measurement	30, 42
voltage/current characteristic	28
falling-edge section	29
non-linear section	29
straight-rise section	29

W

Wheatstone bridge	32
working point stabilization	34

Z

zero-power characteristics	23
zero-power measurement	27